

# SereneLife



## *SLFTRD25*

### Foldable Treadmill

Home Gym Foldable Treadmill  
with 3 Selectable Incline Levels

USER MANUAL

## **IMPORTANT**

**Before installation and operation, please read this operation manual carefully and save this manual for future reference.**

### ***Warning and Safety Information***

1. Ensure that you read the manual carefully before attempting to assemble or use Foldable Treadmill.
2. The Foldable Treadmill must be positioned on a firm flat surface.
3. The Foldable Treadmill is designed for indoor use only. It is not to be used outdoors.
4. Do not position the Foldable Treadmill on a deep thick carpet as air needs to be able to circulate underneath.
5. Always wear the correct clothing when using the Foldable Treadmill. Do not wear loose or long clothing as this may get caught in the moving belt.
6. Always ensure that correct foot wear is worn.
7. Do not stand on the Foldable Treadmill belt before operating. Position your feet on either side of the Treadmill belt and as the motor starts step onto the treadmill. Do not step on the belt if the Foldable Treadmill is at full speed.
8. Before running on the Foldable Treadmill make sure that the emergency cord is attached to you. If the emergency magnet becomes detached from the control panel the treadmill will then stop.
9. Do not allow children or pets near the Foldable Treadmill when in use.
10. Children and elderly should only use the Foldable Treadmill under adult supervision.
11. Always unplug the Foldable Treadmill from the main power supply when not in use.
12. Regularly clean the Foldable Treadmill after use. Remove any dust and sweat from the handles and the running belt. Use a light soapy water mixture to clean the running belt.  
**NEVER USE A ROUGH CLEANING AGENT.**
13. When the Foldable Treadmill is not in use for an extended period fold away it away and store in a clean dry place.

14. If any part of the electrical cable or plug is loose or becomes worn, do not use the Foldable Treadmill and have a qualified electrician inspect the problem.
15. The Foldable Treadmill is not a toy and is not intended for use by persons (including children) with any physical or mental conditions. The Foldable Treadmill should not be used by any person who has not read and understood the manual.
16. If the user has had any prior medical condition they should consult a doctor before use.

## Parts List

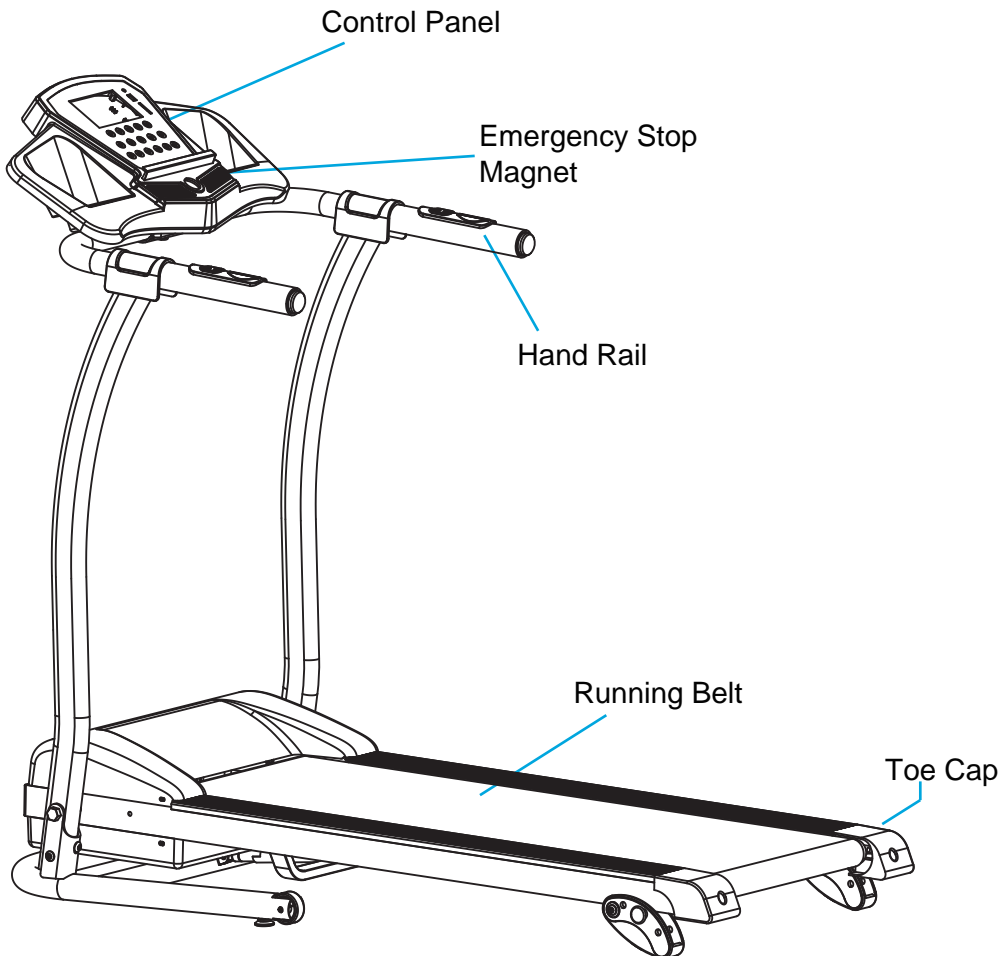

## Accessories

**S1**

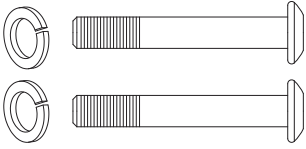

M8x50 Allen Bolt  
X 2

**S2**

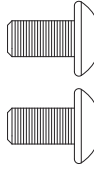

M8x16 Allen Bolt  
X 2

**S3**

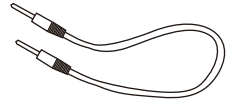

Audio Line  
X1

**S4**



M6x20 screw  
X 2

**S5**

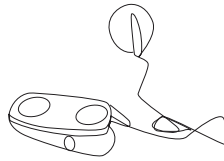

Red emergency stop magnet  
X 1

**S6**

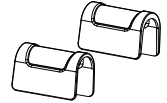

Handle Cover  
X 2

**S7**

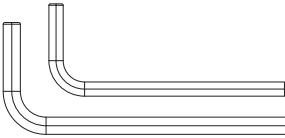

#5 / #6 Hex Key  
X 1

## Assembly Instructions

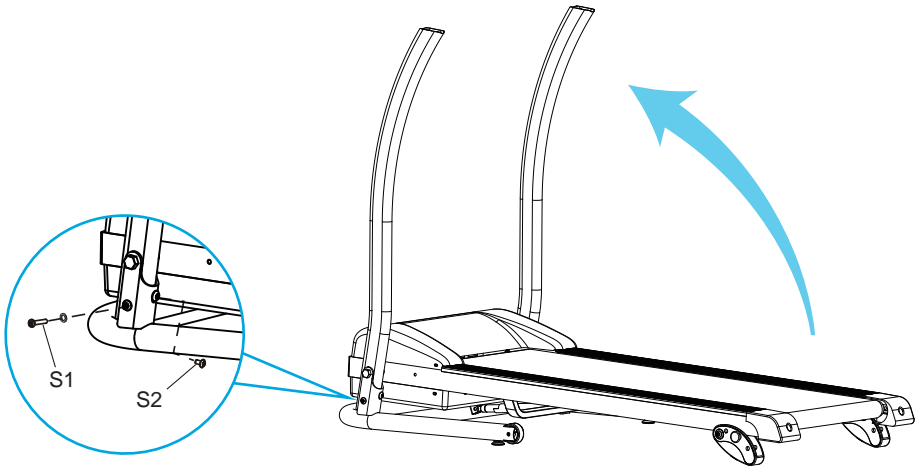

1. Pick up the post, put the M8X16 screw(S2) through the post screw hole, Tighten nut by using # 5 wrench Multi-function wrench. Use # 6 wrench screw(S1) twist into column joints.

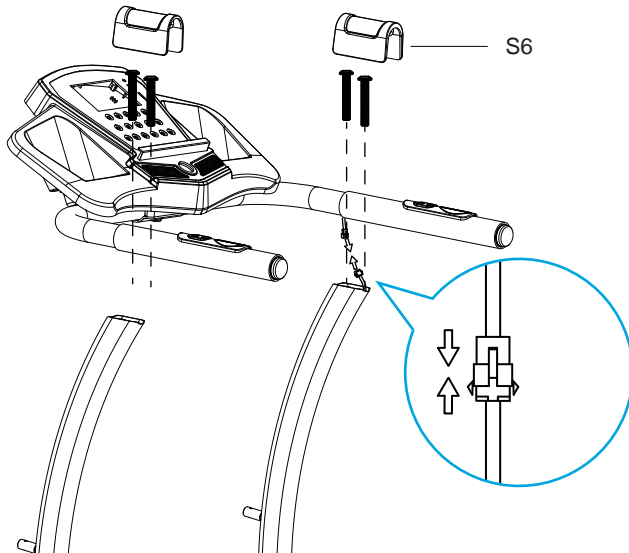

2. Mount the handrail on frame leg and tighten screw with accompanying Allen key(found in the accompanying bag). Insert the crystal head of the handrail into the right side of the column crystal hole ,and insert the decorative covers(S6) of the the handrail.

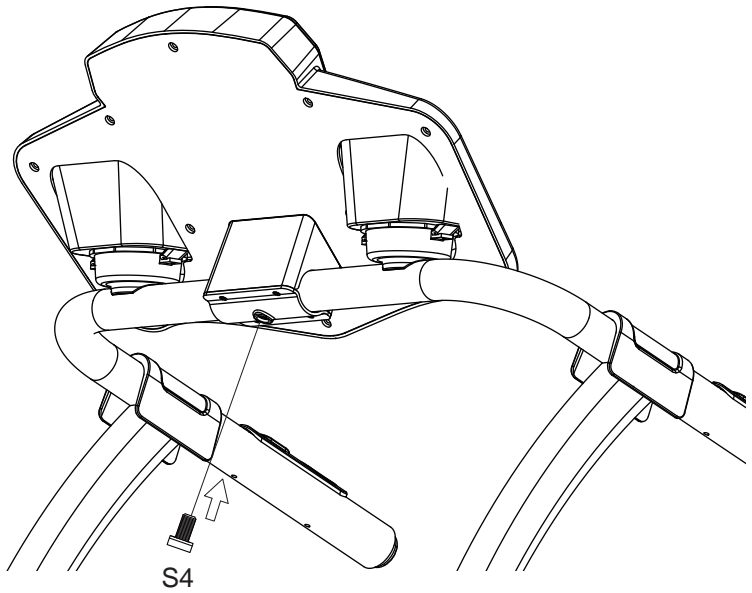

3. Mounting the control panel Align the control panel with the screw hole, screwing in place tightly by hand.

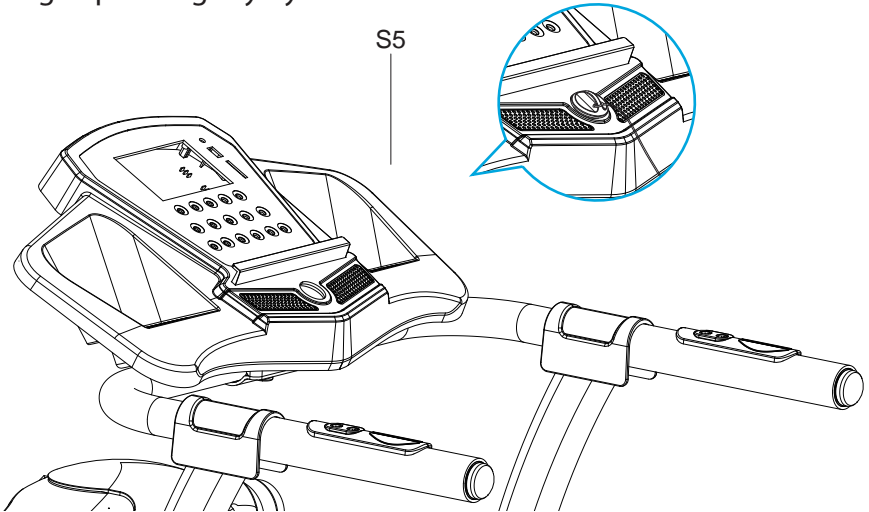

4. Put the Emergency Stop Magnet(S5) on the control panel.  
Perfect machine with finished assembly.

## Control Panel



### **OPERATING THE COMPUTER**

Flip the **Master Power Switch** that is located at the front of the treadmill to the ON position. Before beginning a workout session ensure that the Safety Tether Key is properly placed onto the Computer Console and the Safety Clip is securely attached to an article of your clothing.

#### **NOTE:**

***Always stand on the side rails when you start the treadmill, never start the treadmill while you are standing on the running belt.***

## **QUICK START**

Press the **START** button on the computer to start exercise, the LCD window will countdown 3 seconds with the LCD showing "3-2-1" before the running belt starts moving.

The running belt starts moving with an initial speed of 0.6 MPH. Always allow the treadmill to reach a speed of 0.6 MPH before stepping on to the running belt. You may press the **SPEED +** or **SPEED -** button on the computer console or handlebar to increase or decrease the running speed during exercise. The split window of **SPEED** will display your current running speed. The speed range is from the minimum 0.6 MPH to the maximum 7.5 MPH. You may also press one of the **INSTANT SPEED** buttons (2 / 3 / 4 / 5 / 6) on the computer console and the split window of **SPEED** will display the speed that you have pressed and the running speed will change to 2 MPH, 3 MPH, 4 MPH, 5 MPH, or 6 MPH respectively. The split window of **TIME** will display your elapsed workout time in minutes and seconds. The split window of **DISTANCE** will display the accumulative distance travelled during workout. The split window of **CALORIES** will display the total accumulated calories burned during workout. The split window of **PULSE** will display your current heart rate in beats per minute (BPM). To activate, grip the hand pulse sensors on both handlebars during exercise and the pulse will display after 4-5 seconds. For a more accurate reading, grip pulse sensors with both hands. During training, you may press the **STOP** button on the computer console to stop the treadmill running at any time, or pull out the safety tether key to stop the treadmill running.

## **FUNCTION BUTTONS:**

- **START:**

Press the **START** button to start training on different training mode.

- **STOP:**

Press the **STOP** button to stop training on different training mode.

- **PROG (PROGRAM):**

Press the **PROG** button to select the pre-set training program (P01-P16) mode before training.



- **MODE:**

Press the **MODE** button to select different functions (time, distance, or calories) for setting exercise goals in manual program mode before training.

- **SPEED + (SPEED UP):**

Press the **SPEED +** button to make upward adjustments for pre-setting target training time, distance, or calorie in manual program mode before training. Press the **SPEED +** button to make upward adjustments for pre-setting target training time in pre-set training program (P01-P16) mode before training. Makes speed adjustments during all training periods on different training modes. The speed range is from 0.6 MPH to 7.5 MPH.

- **SPEED - (SPEED DOWN):**

Press the **SPEED -** button to make backward adjustments for pre-setting target training time, distance, or calorie in manual program mode before training. Press the **SPEED -** button to make backward adjustments for pre-setting target training time in pre-set training program (P01-P16) mode before training. Makes speed adjustments during all training periods on different training modes. The speed range is from 0.6 MPH to 7.5 MPH.

- **INSTANT SPEED (2 / 3 / 4 / 5 / 6):**

Used to reach desired speed more quickly.

- **DISPLAY FUNCTIONS:**

**TIME:** Displays your elapsed workout time in minutes and seconds. Press the **START** button on the computer to begin exercising, the LCD window will countdown 3 seconds with the LCD showing "3-2-1" before the running belt starts moving. The running belt starts moving with an initial speed of 0.6 MPH. You may press the **SPEED +** or **SPEED -** button on the computer console or handlebar to increase or decrease the running speed during exercise. Time starts counting up from 0:00 to 99:59 per 1 second increment

- **SPEED:** Displays the current speed from the minimum 0.6 MPH to the maximum 7.5 MPH. You may increase or decrease the speed by pressing the **SPEED +** or **SPEED -** button on the computer console or handlebar.

- **DISTANCE:** Displays the accumulative distance travelled during workout. Press the **START** button on the computer to begin exercising, the LCD window will countdown 3 seconds with the LCD showing "3-2-1" before the running belt starts moving. The running belt starts moving with an

initial speed of 0.6 MPH. You may press the **SPEED +** or **SPEED -** button on the computer console or handlebar to increase or decrease the running speed during exercise. Distance starts counting up.

- **CALORIES:** Displays the total calories burned during your workout. Press the **START** button on the computer to begin exercising, the LCD window will countdown 3 seconds with the LCD showing "3-2-1" before the running belt starts moving. The running belt starts moving with an initial speed of 0.6 MPH. You may press the **SPEED +** or **SPEED -** button on the computer console or handlebar to increase or decrease the running speed during exercise. Calorie starts counting up. (This data is a rough guide for comparison of different exercise sessions and should not be used in medical treatment).

- **PULSE:** Displays your current heart rate in beats per minute (**BPM**). To activate, grip the hand pulse sensors during exercise and the pulse will display after 2-5 seconds. For a more accurate reading, grip pulse sensors with both hands.

### **TRAINING IN MANUAL PROGRAM MODE:**

*You may pre-set target **TIME**, **DISTANCE**, or **CALORIES** in **STOP** mode before training. Only one of the functions can be pre-set.*

To set **TIME** press the **MODE** button on the computer console until you see the split window of **TIME** starts blinking. Press the **SPEED +** or **SPEED -** button on the computer console or handlebar to change the setting. Each increment is 1 minute. The pre-set target time range is from 5:00 to 99:00 minutes. Once you pre-set target time, press the **START** button on the computer to begin exercising. The running belt starts moving with an initial speed of 0.6 MPH. You may press the **SPEED +** or **SPEED -** button on the computer console or handlebar to increase or decrease the running speed during exercise. Time starts counting down from pre-set target time to 0:00 per 1 second backward. When the pre-set target time counts down to 0:00, the computer will beep to alert you and the treadmill will stop automatically.

To set **DISTANCE** press the **MODE** button on the computer console until you see the split window of **DISTANCE** begin blinking. Press the **SPEED +** or **SPEED -** button on the computer console to change the setting. The pre-set target distance range is from 0.50 to 99.5 mile, the default distance

is 1 mile. Once you pre-set target distance, press the **START** button on the computer to begin exercising. The running belt starts moving with an initial speed of 0.6 MPH. You may press the **SPEED +** or **SPEED -** button on the computer console or handlebar to increase or decrease the running speed during exercise. Distance starts counting down from pre-set target distance to 0.00. When the pre-set target distance counts down to 0.00, the computer will beep to alert you and the treadmill will stop automatically.

To set **CALORIES** press the **MODE** button on the computer console until you see the split window of **CALORIES** begin blinking. Press the **SPEED +** or **SPEED -** button on the computer console to change the setting. The pre-set target calorie range is from 10 to 995 calories. Once you pre-set target calories, press the **START** button on the computer to begin exercising. The running belt starts moving with an initial speed of 0.6 MPH. You may press the **SPEED +** or **SPEED -** button on the computer console or handlebar to increase or decrease the running speed during exercise. calories start counting down from pre-set target calories to 0. When the pre-set target calories counts down to 0, the computer will beep to alert you and the treadmill will stop automatically.

### ***TRAINING IN MANUAL PROGRAM MODE:***

The computer offers 16 pre-set programs (P01-P16). You may select one of the pre-set training programs in **STOP** mode before training. Press the **PROG (PROGRAM)** button on the computer console to select one of the training programs. The split window of **TIME** begin blinking. You may press the **SPEED +** or **SPEED -** button on the computer console or handlebar to change the setting. Each increment is 1 minute. The pre-set target time range is from 5:00 to 99:00 minutes. Once you pre-set target time, press the **START** button on the computer to begin exercising.

The running speed will change automatically during the workout (as shown below). The program is split evenly into 20 intervals. You may press the **SPEED +** or **SPEED -** button on the computer console or handlebar to increase or decrease the running speed during exercise. When the pre-set training program time count down to 0:00, the computer will beep to alert you and the treadmill will stop automatically.

# Unfolding/Folding the Machine

## 1. Unfolding the Machine

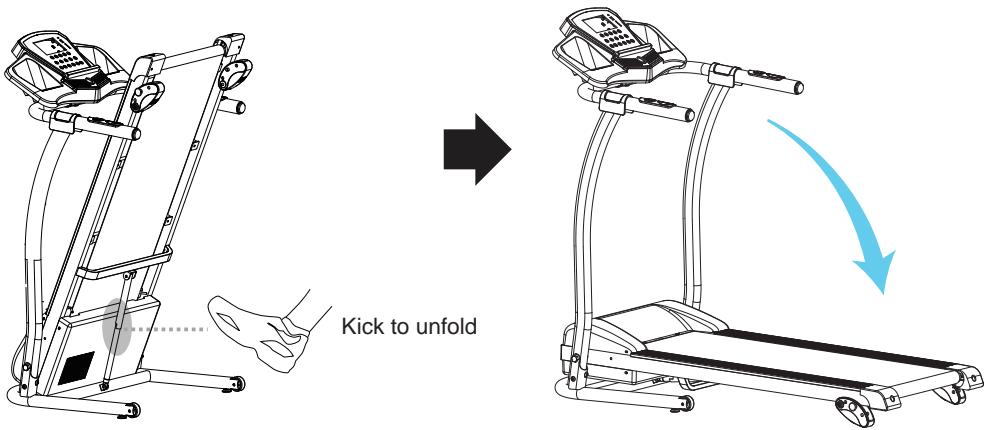

## 2. Folding the Machine

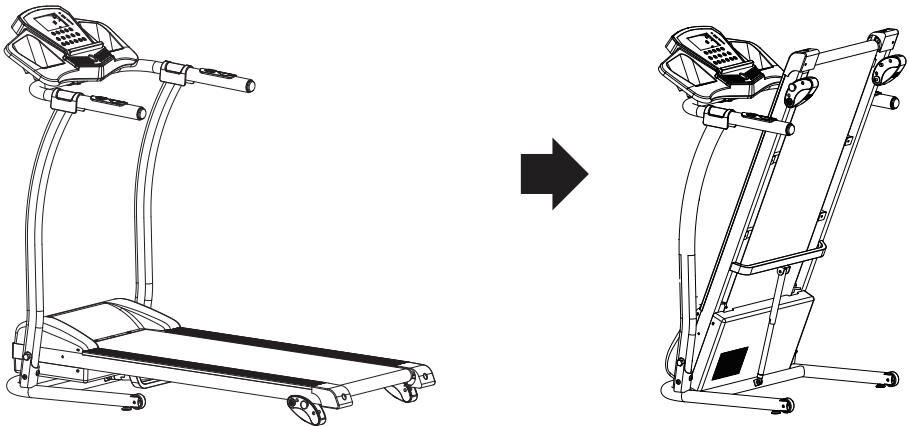

1. Before moving or cleaning your **Foldable Treadmill** unplug it from the main power supply.
2. Always clean the **Foldable Treadmill** with a damp cloth avoiding the control panel. **DO NOT USE ROUGH CLEANING AGENTS.**
3. Clean the power switch and control panel with a soft dry cloth. **DO NOT USE WET CLOTH IN THESE AREAS.**
4. Do not use your treadmill in wet, damp conditions or high dust areas as this can cause damage to the **Foldable Treadmill**.

## Adjusting the Running Belt

1. The running belt on the **Foldable Treadmill** will shift slightly after continuous use. **This is normal for all treadmills.**
2. To straighten/adjust the running belt turn the adjusting bolt on either side of the base, see figure C and D.

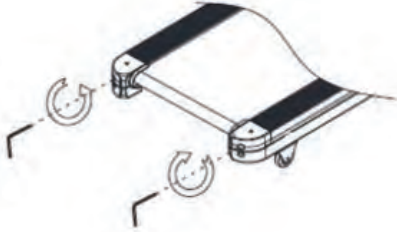

**Picture C**

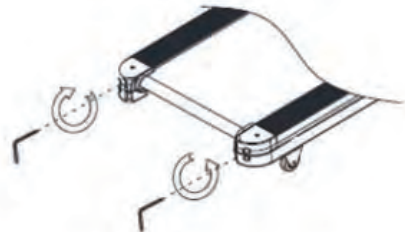

**Picture D**

3. Do not allow for the running belt to catch the sides of the **Foldable Treadmill** as this will tear the belt.

### **STORAGE:**

Remember to store the treadmill in a dry place and not to pile things on top of it.

### **Compatible Fitness Application**



### **ANDROID:**

Download your favorite application from Google Playstore.

### **iPad/iPhone:**

Download your favorite application from the AppStore.

Check if your mobile device confirms the requirements of the application. The requirements of each application are shown in the Google Playstore or AppStore.

## **How to Use:**

- Turn ON the Bluetooth function of your mobile device.
- Open the application on your device.
- Click on in the main menu on the button “Indoor” to search for available devices.



Choose the shown device from the list to pair it.

Once the device is paired you can start using the application in different categories:

- **Quick Run**
- **Map Mode**
- **Target Mode**

Please understand that we are not able to offer you a complete operation guide of the application inside this manual, as the app will be updated from time to time. This process can make changes to the operation or the design of the application.

Please refer to the instructions inside the specific app download store or contact us.

---

## **SLFTRD25**

### **Foldable Treadmill**

#### **Home Gym Foldable Treadmill with 3 Selectable Incline Levels**

#### **Features:**

- Get Connected with the 'iFitShow' App
- Pairs to Your Device via Bluetooth Connectivity
- Running & Training Data Statistics Readout
- 3 Manual Selectable Inclined Levels for Runner Difficulty
- Built-in Hand Grip Sensors for Pulse Monitoring
- 5" Digital LCD Display Screen with Touch Button Controls
- Displays Run Time, Distance, Speed, Calories Burned, Heart Rate
- Adjustable Speed Settings
- Selectable 16 Preset Training programs
- Simple Electric Motorized Plug-in Design
- Convenient Folding Style for Easy Setup & Storage

- Used for Walking, Jogging, Running, Exercise, Training
- Perfect for Weight Loss, Cardiovascular Fitness, Endurance & Stamina Building
- Integrated Safety Key, Emergency Power Off
- Removable Book / Tablet Device Holder
- MP3,USB Flash, SD Card Port
- Built-In Speakers for Auxiliary Devices

### **The 'iFitshow' App:**

- Train Smarter and Connect via Your Favorite Device
- Works with Smartphones, Tablets, Laptops, etc.
- Free to Download via Your Smartphone
- Multifunctional Sports App
- Connect to the Treadmill via Smart BTM Bluetooth
- App Provides Access to Exercise Activities
- Linked to 'HealthKit' to Record and Collect Activity Data
- Easily Share Health and Fitness Data via Social Media
- Available for iOS and Android

### **Bluetooth Connectivity:**

- Hassle-Free Pairing, No Password Required
- Compatible with All of Today's Latest Bluetooth Devices (Smartphones, Tablets, Laptops, Computers, etc.)
- Bluetooth Version: BLE4.0
- Wireless Range: Up to 16.4' ft.

### **Technical Specs:**

- Motorized Treadmill Motor Power: 1.5HP
- Running Belt / Running Surface Size (L x w): 43.3" x 15.7" -inches
- Motor Power: 1.5 HP
- Adjustable Speed: 0.6 – 7.5 mph
- Maximum Weight Support: Up to 265 lbs.
- \*Some Assembly Required
- Power Supply: 100-120V
- Total Folded Dimensions (L x W x H): 25.6" x 26.7" x 52.3" -inches
- Total Open Dimensions (L x W x H): 54.7" x 26.7" x 49.6" -inches
- Assembled Weight: 70.5 lbs.



SereneLife