

# JVC



ENGLISH

FRANÇAIS

ESPAÑOL

**FM CORDLESS HEADPHONES**  
**CASQUE FM SANS FIL**  
**AURICULARES INALÁMBRICOS FM**

# HA-W600RF-J/C



For customer Use:  
Enter below the Model No. and  
Serial No. which are located on the  
top or bottom of the cabinet. Retain  
this information for future reference.

Model No. \_\_\_\_\_  
Serial No. \_\_\_\_\_



**INSTRUCTIONS**  
**MANUEL D'INSTRUCTIONS**  
**MANUAL DE INSTRUCCIONES**

LNT0066-001A

# Warnings, cautions and others

## Mises en garde, precautions et indications diverses

### Avisos, precauciones y otras notas

|  |   |   |
|--|---|---|
|   | <b>CAUTION</b><br>RISK OF ELECTRIC SHOCK<br>DO NOT OPEN |  |
| <p>CAUTION: TO REDUCE THE RISK OF ELECTRIC SHOCK,<br/>DO NOT REMOVE COVER (OR BACK).<br/>NO USER SERVICEABLE PARTS INSIDE.<br/>REFER SERVICING TO QUALIFIED SERVICE PERSONNEL.</p> |   |   |



The lightning flash with arrowhead symbol, within an equilateral triangle is intended to alert the user to the presence of uninsulated "dangerous voltage" within the product's enclosure that may be of sufficient magnitude to constitute a risk of electric shock to persons.



The exclamation point within an equilateral triangle is intended to alert the user to the presence of important operating and maintenance (servicing) instructions in the literature accompanying the appliance.

**WARNING: TO REDUCE THE RISK OF FIRE OR ELECTRIC SHOCK, DO NOT EXPOSE THIS APPLIANCE TO RAIN OR MOISTURE.**

#### FCC INFORMATION

This device complies with Part 15 of the FCC Rules. Operation is subject to the following two conditions:

- (1) This device may not cause harmful interference
- (2) This device must accept any interference received, including interference that may cause undesired operation.

**CAUTION:** Changes or modifications not approved by JVC could void user's authority to operate the equipment.

#### Contact

Address: JVC AMERICAS CORP.  
JVC COMPANY OF AMERICA  
1700 Valley Road, Wayne, N.J.  
07470

Telephone: 1 (800) 252-5722

**Note:** This equipment has been tested and found to comply with the limits for a Class B digital device, pursuant to Part 15 of the FCC rules. These limits are designed to provide reasonable protection against harmful interference in a residential installation. This equipment generates, uses and can radiate radio frequency energy and, if not installed and used in accordance with the instructions, it may cause harmful interference to radio communications. However, there is no guarantee that interference will not occur in a particular installation. If this equipment does cause harmful interference to radio or television reception, which can be determined by turning the equipment off and on, the user is encouraged to try to correct the interference by one or more of the following measures:

- Reorient or relocate the receiving antenna.
- Increase the separation between the equipment and receiver.
- Connect the equipment into an outlet on a circuit different from that to which the receiver is connected.
- Consult the dealer or an experienced radio/TV technician for help.

## IC INFORMATION

This device complies with RSS-210 of the IC Rules. Operation is subject to the following two conditions:

- (1) This device may not cause harmful interference
- (2) This device must accept any interference received, including interference that may cause undesired operation of the device.

**CAUTION:** Changes or modifications not approved by JVC could void user's authority to operate the equipment.

### Contact

Address: JVC CANADA INC.  
21 Finchdene Square,  
Toronto, ON M1X 1A7

Telephone: (416) 293-1311

e-mail: info@jvc.ca

**Note:** This equipment has been tested and found to comply with the limits for a Class B digital device, pursuant to Industry Canada's RSS-210. These limits are designed to provide reasonable protection against harmful interference in a residential installation. This equipment generates, uses and can radiate radio frequency energy and, if not installed and used in accordance with the instructions, it may cause harmful interference to radio communications. However, there is no guarantee that interference will not occur in a particular installation. If this equipment does cause harmful interference to radio or television reception, which can be determined by turning the equipment off and on, the user is encouraged to try to correct the interference by one or more of the following measures:

- Reorient or relocate the receiving antenna.
- Increase the separation between the equipment and receiver.
- Connect the equipment into an outlet on a circuit different from that to which the receiver is connected.
- Consult the dealer or an experienced radio/TV technician for help.

## INFORMATION SUR IC

Cet appareil est conforme à la RSS-210 du règlement de la IC. Le fonctionnement est sujet aux deux conditions suivantes:

- (1) Cet appareil ne peut causer d'interférences nuisibles
- (2) Cet appareil reçoit toute interférence même les interférences qui peuvent occasionner un mauvais fonctionnement.

**ATTENTION:** Les changements ou les modifications non approuvés par JVC risquent de retirer à l'utilisateur le droit d'utiliser l'appareil.

### Contact

Adresse: JVC CANADA INC.  
21 Finchdene Square, Toronto,  
ON M1X 1A7

Téléphone: (416) 293-1311

e-mail: info@jvc.ca

**Remarque:** L'appareil a été testé et jugé conforme aux limites des appareils numériques de classe B, aux termes de la réglementation RSS-210 de l'industrie du Canada. Ces limites ont pour but d'assurer une protection raisonnable contre les interférences parasites lorsque l'appareil est utilisé dans une installation résidentielle. Cet appareil engendre, utilise et peut émettre une énergie radioélectrique et, s'il n'est pas installé et utilisé en stricte conformité avec ces instructions, il peut provoquer des interférences parasites dans les liaisons radiophoniques. Ceci ne garantit pas pour autant qu'une installation particulière n'émettra aucune interférence. Si l'appareil engendre des interférences parasites avec la réception radio ou télévision, ce qui pourra être déterminé en éteignant puis en rallumant l'appareil, il est conseillé à l'utilisateur d'essayer de corriger les interférences en prenant l'une des mesures ci-dessous:

- Modifier l'orientation ou changer l'emplacement de l'antenne de réception.
- Eloigner davantage l'appareil du récepteur.
- Brancher l'appareil dans une prise d'un circuit différent de celui auquel le récepteur est raccordé.
- Demander l'aide de son agent ou d'un technicien radio/télévision qualifié.

## IMPORTANT

### CAUTION:

TO PREVENT ELECTRIC SHOCK DO NOT USE THIS PLUG WITH AN EXTENSION CORD, RECEPTACLE OR OTHER OUTLET UNLESS THE BLADES CAN BE FULLY INSERTED TO PREVENT BLADE EXPOSURE.

### ATTENTION:

POUR PREVENIR LES CHOCS ELECTRIQUES NE PAS UTILISER CETTER FICHE AVEC UN PROLONGATEUR, UNE PRISE DE COURANT OU UNE AUTRE SORTIE DE COURANT, SAUF SI LES LAMES PEUVENT ETRE INSEREES A FOND SANS EN LAISSER AUCUNE PARTIE A DECOUVERT.

- (1) This device may not cause interference.
- (2) This device must accept any interference, including interference that may cause undesired operation of the device.
- (1) Ce produit ne cause pas d'interférence.
- (2) Ce produit doit accepter toute interférence, incluant interférence qui peut causer opération non désiré.

## ENGLISH

This product's performance would be degraded under a strong electro-static environment. And the function would be self-recoverable after the above case.

This product's performance would be degraded since the disturbance from the mains cord. And the function would be self-recoverable after the above case.

## FRANÇAIS

Les performances de ce produit se détérioreront dans un environnement fortement électro-statique. Par ailleurs, le fonctionnement se restaurera de lui-même dans le cas ci-dessus.

Les performances de ce produit se détérioreront en cas de perturbations du cordon d'alimentation. Par ailleurs, le fonctionnement se restaurera de lui-même dans le cas ci-dessus.

## ESPAÑOL

El rendimiento de este producto puede deteriorarse en un entorno con campos electrostáticos fuertes. El funcionamiento se repondrá a la normalidad después del caso arriba mencionado.

El rendimiento de este producto puede deteriorarse debido a las perturbaciones del cable de la red eléctrica. El funcionamiento se repondrá a la normalidad después del caso arriba mencionado.

### Hearing Comfort and Well-Being

- Do not play your personal audio at a high volume. Hearing experts advice against continuous extended play.
- If you experience a ringing in your ears, reduce volume or discontinue use.

### Traffic safety

- Do not use while operating a motorized vehicle. It may create a traffic hazard and is illegal in many area.
- You should use extreme caution or temporarily discontinue use in potentially hazardous situations.
- Even though your headphones are of the open-air type designed to let you hear outside sounds, don't turn up the volume so high that you can't hear what's around you.

Thank you for purchasing a JVC product.  
Please read all instructions carefully before operation, to ensure your complete understanding and to obtain the best possible performance from the unit.

## FEATURES

- Call Function–Call headphone user with “CALL” button on base station (transmitter)
- Reception range up to 50 m/164 ft. (using JVC measurement system)
- Auto Tuning–Headphones automatically tunes in to the base station (transmitter) as it turns on
- On Stand Charging–Rechargeable system with the exclusive Ni-MH battery that requires no charge cable
- Auto Power On/Off transmitter
- “PLL” Stabilized Transmission Technology
- Auto-level control circuit that automatically adjusts signals to the appropriate modulation level
- Large 40 mm (1.63”) dia. driver unit for high quality sound
- Adaptable to any audio/visual equipment which has the analog audio output.

## Contents

|                                   |           |
|-----------------------------------|-----------|
| <b>Precautions .....</b>          | <b>2</b>  |
| <b>Parts identification.....</b>  | <b>3</b>  |
| <b>Connection.....</b>            | <b>4</b>  |
| <b>Battery installation .....</b> | <b>5</b>  |
| <b>Charging the battery.....</b>  | <b>6</b>  |
| <b>Basic operations .....</b>     | <b>7</b>  |
| <b>Troubleshooting.....</b>       | <b>9</b>  |
| <b>Specifications .....</b>       | <b>10</b> |

### For your health and traffic safety

- Be careful not to turn the sound volume up too high when using the headphones. Your hearing can be damaged by listening to sounds at excessive volume for long periods.
- Never use the headphones when driving a car, motorcycle, or bicycle. This could result in an accident.
- Pay close attention to traffic around you when using the headphones while walking. Not doing so could result in an accident.

# Precautions

## Important cautions

### CAUTION

To reduce the risk of electrical shocks, fire, etc.:

1. Do not remove screws, cover or cabinet.
2. Do not expose this appliance to rain or moisture.

## Precautions

### Installation

- Select a place which is level, dry and neither too hot nor too cold (between 0°C and 35°C (32°F and 95°F)).
- Keep away from direct sunlight.
- Do not put it too close to a heater.
- Indoor use only.

### Power cord

- Do not handle the power cord with wet hands!
- Do not bend the power cord sharply.
- Do not connect the supplied AC adaptor to any other equipment. It is exclusively for use with this unit.

### Malfunctions, etc.

- There are no serviceable parts inside. If anything goes wrong, unplug the power cord and consult your dealer.
- Do not insert any metallic object.
- Do not allow water to get inside.
- Do not move or bend the ear cups or any other part of the headphones with excessive force. It may damage the headphones.
- Stop using the headphones if they are causing discomfort on your skin. Otherwise inflammation or irritation may be caused on your skin.
- The ear pad will wear out earlier than the other parts even in normal use or in normal keeping due to the material characteristics. For replacement of the ear pads, please consult with the dealer where you purchased the headphones.
- If the headphone is not used for a prolonged time, unplug the AC adaptor from an AC outlet.

## Battery precautions

- Be sure to use the supplied exclusive battery. Do not use any other rechargeable or dry cell battery.
- Use only the type of battery the manufacturer recommends when replacing the battery.
- Do not throw the battery in a fire or heat it.
- Do not immerse or wet the battery in water.
- Do not remove or damage the covering tube.
- Do not subject the battery to strong shocks or throw it.
- If any liquid from the battery gets into your eyes, it may cause blindness. If battery liquid does get into your eyes, do not rub them, but instead immediately wash them thoroughly with clean water, then consult a doctor at once. Also, should any liquid from the rechargeable battery get onto your skin or clothes, it may burn your skin. In this case, wash with clean water immediately.
- When discarding batteries, environmental problems must be considered and the local rules or laws governing the disposal of these batteries must be followed strictly.

## Charging precautions

- Charge only with supplied Ni-MH type battery. Other types of battery may burst causing personal injury and damage.
- Use only the supplied base station to charge the battery.
- Be sure to use the supplied AC adaptor.

## Supplied accessories

Check to be sure you have all of the supplied accessories.

The number in parentheses is the quantity of the pieces supplied. If anything is missing, contact your dealer immediately.

- Exclusive rechargeable batteries (2)
- Exclusive AC adaptor (1)
- Connection cord (1)
- Conversion cord (1)
- Plug adaptor (1)

# Parts identification

See pages in parentheses for details.

## Base station (transmitter and battery charging unit)

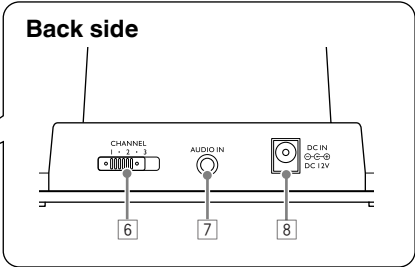
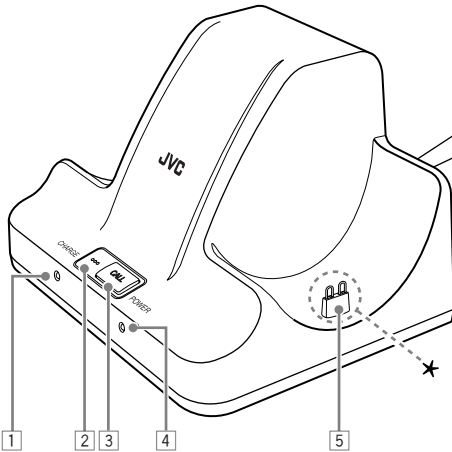

\* The battery charging terminal on the base station is covered with the protection cap when purchasing. Take off the cap before charging.

- 1 CHARGE indicator (6)
- 2 Microphone (8)
- 3 CALL button (8)
- 4 POWER indicator (7)

- 5 Battery charging terminal (6)
- 6 CHANNEL selector (8)
- 7 AUDIO IN jack (4)
- 8 DC IN  $\ominus$   $\oplus$  jack (4)

## Headphones

Left

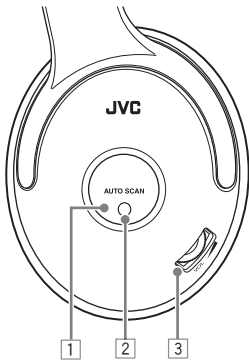

- 1 AUTO SCAN button (7, 8)
- 2 AUTO SCAN indicator (7)
- 3 VOL (volume) (7)
- 4 Ear pad (5)
- 5 Battery charging terminal (6)
- 6 POWER button (6, 7)
- 7 POWER indicator (6, 7)

Right

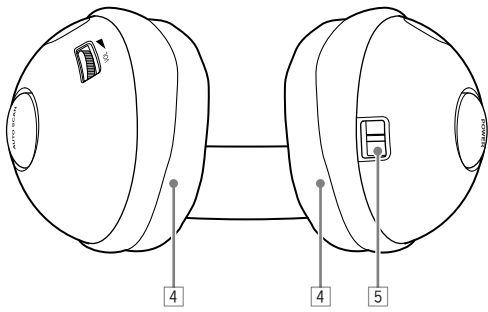
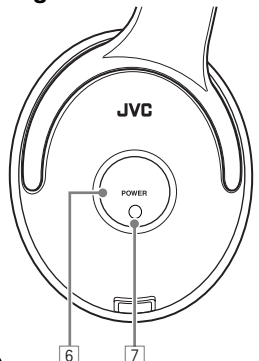

# Connection

**Be sure to connect the AC adaptor after all other connections are complete.**

- 1** Connect the base station to the AV equipment.
- 2** Connect the AC adaptor to the base station.
- 3** Connect the AC adaptor to the AC outlet.

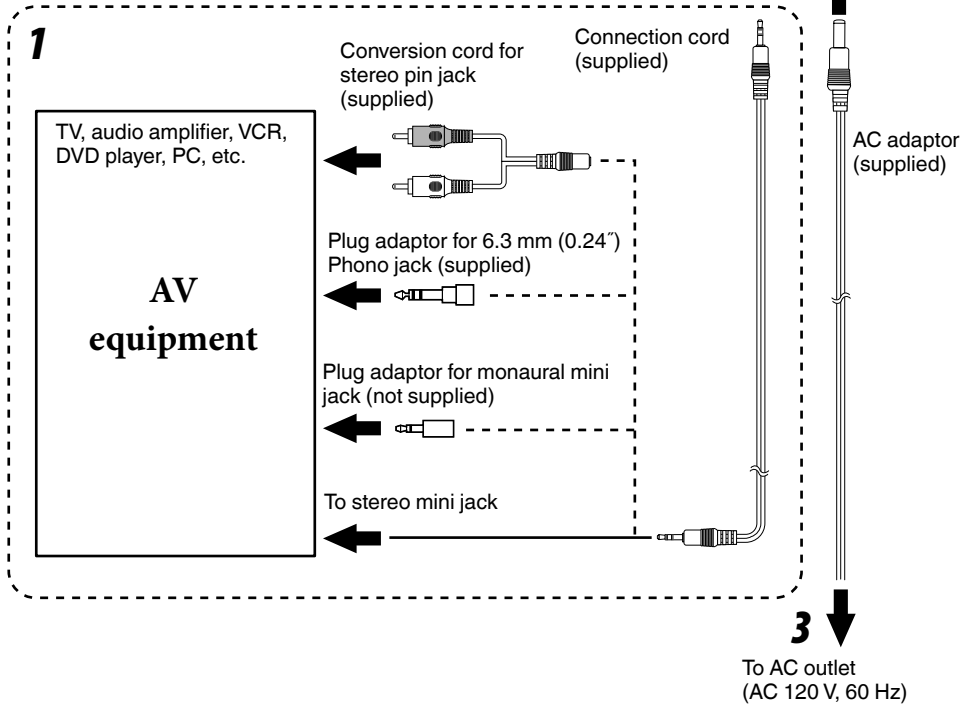
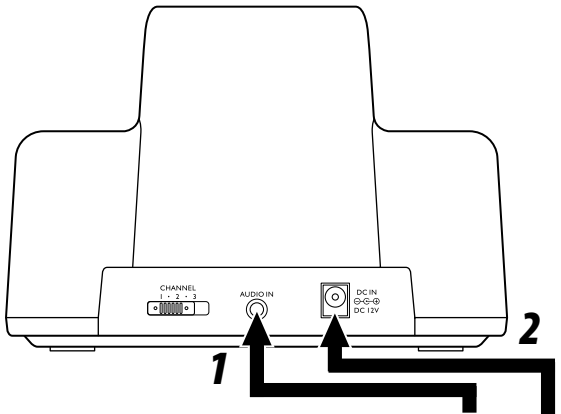

**Note:**  
Do not use any other AC adaptor than the supplied AC adaptor. Otherwise, malfunctions may be caused.



# Battery installation

- 1** Take off the ear pad of the right headphone.

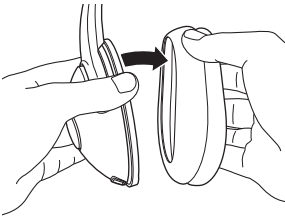

- 2** Take off the battery covers.

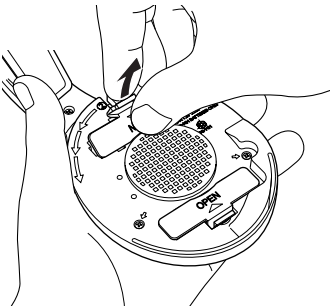

- 3** Install the batteries.

Match the polarity (+ and -) on the batteries with the + and - marking on the battery compartments.

- Insert the - terminal of the battery at first.

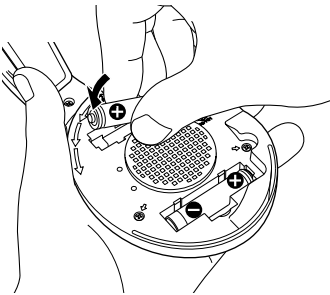

Be sure to use the supplied exclusive battery. Do not use any other rechargeable or dry cell battery, which may cause malfunctions or damage the unit.

- 4** Put on the battery covers.

- 5** Put on the ear pad.

- 1** Insert the hem of the ear pad into the slit on the headphone.

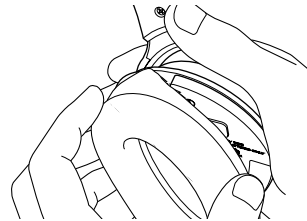
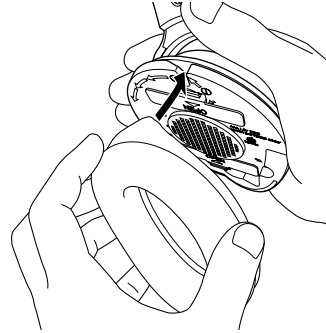

- 2** Turn the ear pad anticlockwise to slide all the hem into the groove on the headphone.

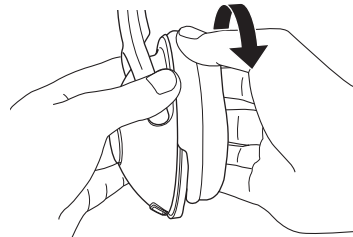
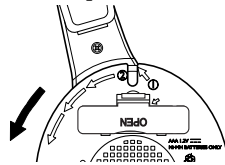

- Be sure that all the hem is inserted fully. If not, turn the ear pad anticlockwise again until all the hem slides in.

# Charging the battery

The base station works as the battery charging unit. Charge the rechargeable battery before starting to use the headphones. You can continuously use the headphones for about 10 hours after full battery charge.

## 1 Make sure that the headphones are turned off.

You cannot charge the battery of the headphones when the headphones are turned on. Press POWER to turn the Power indicator off.

## 2 Put on the headphones on the base station so that their charging terminals contact firmly.

- The battery charging terminal on the base station is covered with the protection cap when purchasing. Take off the cap before charging.
- When putting the headphones on the base station, hold them and adjust their position with your both hands to assure the contact of the terminals.

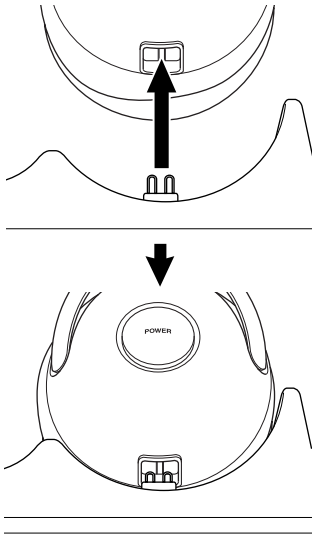

## 3 Confirm the CHARGE indicator lights up.

If the charge indicator does not light up, return steps 1 and 2 after checking the connection of the AC adaptor.

- It takes about 30 hours to charge the batteries fully.
- 30-hour charging may not charge the battery fully depending on the battery or other conditions.
- The cycle life of the rechargeable battery is approximately 500 times. (It varies depending on the conditions when charging.)
- The battery leaks its charge little by little even when the headphones' power is off, due to its characteristics.

### Notes on the battery and charging

- To make battery life longer:
    - charging the battery within the temperature range of 10°C – 35°C (50°F – 95°F).
    - not using the headphones in excessively cold places. Low temperature decreases battery life.
    - charging the battery after its complete discharging. Charging before complete discharge makes the battery life gradually shorter.
  - Replace the batteries when their lives become about half or the playback sound become constantly noisy.
- Use the exclusive rechargeable Ni-MH battery J47958 only.** When purchasing the battery, consult the dealer where you bought the product.
- Replace two batteries at the same time when replacing.

# Basic operations

## Listening to the sound from the base station

The base station works as the FM transmitter and send sound to the headphones.

### Precaution

Turn down the volume of the headphones with the VOL dial before turning on its power to avoid excessive volume.

## 1 Start playback on the AV equipment connected with the base station.

The base station turns on automatically and starts to transmit FM signals (Auto Power On function).

The POWER indicator of the base station lights up.

- In some situations, the power may not be turned on automatically by the input sound (e. g. a song with a quiet opening or fade in). This is not a malfunction.

## 2 Press POWER on the headphones to turn on the power.



The POWER indicator lights up and the headphones automatically starts to tune in to the signal from the base station (Auto Tuning function).

The AUTO SCAN indicator lights up when tuned in.

- **Press the center of the button firmly when pressing POWER. Pressing the edge may not turn on the power.**
- Charge the battery in the following cases.  
The battery ran out:
  - The POWER indicator does not light up after pressing POWER.
  - The AUTO SCAN indicator does not light up though the POWER indicator lights up.

- No sound is heard while Auto Tuning. It takes a few seconds to tune in.
- Press AUTO SCAN when the sound does not come out properly.



## 3 Adjust the volumes of the AV equipment and the headphones.



- Adjust the volumes within the area about 7 m (23 ft.) from the base station to get optimum signal reception.
- You can get better sound by setting the volume of the AV equipment as high as possible without causing distortion and that of the headphone lower (except when connecting the AV equipment through LINE OUT jacks).

### To Turn off the units

Press POWER on the headphones and stop playback on the AV equipment. The headphones' POWER indicator goes off.



- The base station automatically turns off if no signals come in for about four minutes (Auto Power OFF function).
- The white noise may come out when the base station turns off. Take off and turns off the headphones after using.

# Basic operations

## Selecting a better reception channel

When the playback sound is noisy, you can choose one of the other two channels to transmit signals on the base station.

- The white noise may come out when switching the channel. Take off the headphones when switching the channel.

**1** Slide the **CHANNEL** selector on the back side of the base station to select another channel.



**2** Press **AUTO SCAN** on the headphones to tune in to the new channel.



**3** Repeat Steps 1 and 2 to select the best channel.

### Listening area

The headphones can receive the FM signal of the base station 50 m (164 ft.) away from it at maximum (when no interference or obstacles exist between them). But the receivable range becomes shorter or reception quality becomes poorer in the following cases:

- In places such as reinforced concrete buildings
- Obstacles such as steel-reinforced doors exist between the base station and headphones
- Items such as metal furniture are situated nearby
- In places facing a street
- Noise or interference sources exist nearby (e.g. mobile ham, radio stations, high-voltage power lines, a microwave oven, cordless phones, cellular phones, etc.)

## Call through the base station

You can call the one using the headphones with the microphone on the base station.

**1** Press and hold **CALL** on the base station.



The playback sound is interrupted.

**2** Speak to the microphone on the base station.

Speak at least 10 cm (4 inches) away from the microphone. The speaking sound may be distorted.

**3** Release **CALL** after finishing speaking.



- Do not speak to the microphone suddenly in too loud voice. The sudden excessive loud sound may damage the ears of the headphones user or may cause an accident to the user.
- Do not use the Call function when the headphones are near the base station. It may cause a howling sound and damage the headphone user or cause an accident.

# Troubleshooting

What appears to be trouble is not always serious. Check the following points before calling a service center.

| Symptom                            | Cause/Remedy   |
|------------------------------------|--|
| No sound comes out at all.         | <ul style="list-style-type: none"><li>• Turns on the power of the headphones.</li><li>• Start playback on the AV equipment connected to the base station.</li><li>• Check the connection between the base station and the AV equipment.</li><li>• Turns up the volume of the headphones or the connected AV equipment to an appropriate level.</li><li>• Fully charge the headphones' battery.</li></ul>   |
| No sound comes out from R-channel. | <ul style="list-style-type: none"><li>• Check the connection between the base station and the AV equipment.</li><li>• Sound comes out only of L-channel when the base station is connected to the monaural audio output. Convert the mini plug to the base station from stereo to monaural with the plug adaptor (not supplied).</li></ul>   |
| Sound is distorted.                | <ul style="list-style-type: none"><li>• The headphones' battery will soon run out. Fully charge the battery.</li><li>• The volume of the headphones and/or the connected AV equipment is too high. Adjust their volume to an appropriate level.</li></ul>  |
| Sound is noisy.                    | <ul style="list-style-type: none"><li>• The headphones' battery will soon run out. Fully charge the battery.</li><li>• Switch the base station channel to another and press AUTO SCAN on the headphones.</li><li>• The volume of the connected AV equipment is too low. Adjust the volume as high as possible without causing distortion.</li><li>• Too far from the base station. Use the headphones within the range of the base station (see page 8).</li></ul> |
| Cannot charge the battery.         | <ul style="list-style-type: none"><li>• Check the contact of the charging terminals on the base station and the headphones.</li><li>• Check the polarity of the battery.</li><li>• The cycle life of the battery ended. Replace with the new battery (see page 6).</li></ul>   |

# Specifications

## General Specifications

|                                  |  |
|----------------------------------|--|
| Modulation system:               | Stereo frequency modulation system   |
| Carrier frequency:               | 912.0 MHz (Channel 1)<br>912.5 MHz (Channel 2)<br>913.0 MHz (Channel 3)                  |
| Usable area (distance to reach): | Max. 50 m (164 ft.) (using JVC measurement systems, under controlled ambient conditions) |
| Frequency response:              | 25 Hz – 13,000 Hz  |
| Distortion:                      | Less than 3% (at 1 kHz)  |

## Transmitter (J22320-001)

|                        |  |
|------------------------|--|
| Power requirements:    | DC 12 V (with the exclusive AC adaptor)                      |
| Audio input terminals: | 3.5 mm (0.13") dia. stereo mini jack                         |
| Input impedance:       | 36 k $\Omega$  |
| Reference input level: | 350 mV   |
| Dimensions:            | 159 (W) mm x 114 (D) mm x 123 (H) mm (6.26" x 4.49" x 4.84") |
| Mass:                  | 280 g (9.9 oz) (without connection cord and AC adaptor)      |

## Headphones

|                       |  |
|-----------------------|--|
| Power requirements:   | Rechargeable Ni-MH battery (1.2 V) x 2     |
| Battery running time: | 10 hours (when charged for 30 hours)       |
| Mass:                 | 250 g (8.8 oz) (with rechargeable battery) |

## Supplied Accessories

- Instructions x 1
- Exclusive AC adaptor x 1 (J34675-001: AC 120 V, 60 Hz, 4 W)
- Exclusive rechargeable Ni-MH battery x 2
- Connection cord x 1 (3.5 mm (0.13") dia. stereo mini plug: 2.2 m (7.22 ft))
- Conversion cord x 1 (3.5 mm (0.13") dia. stereo mini jack — RCA pin plug x 2: 0.1 m (0.33 ft))
- Plug adaptor x 1 (converts 3.5 mm (0.13") dia. stereo mini plug to a 6.3 mm (0.24") dia. standard stereo phone plug)

\* Design and specifications subject to change without notice.

HA-W600RF-J/C | FM CORDLESS HEADPHONES

**JVC**

# JVC



**FM CORDLESS HEADPHONES  
FUNKKOPFHÖRER  
DRAADLOZE FM-HOOFDTELEFOON  
CASQUE FM SANS FIL  
CUFFIE SENZA FILO FM  
TRÅDLÖSA FM-HÖRLURAR**

## HA-W600RF-G



ENGLISH

DEUTSCH

NEDERLANDS

FRANÇAIS

ITALIANO

SVENSKA

**INSTRUCTIONS  
BEDIENUNGSANLEITUNG  
GEBRUIKSAANWIJZING  
MANUEL D'INSTRUCTIONS  
ISTRUZIONI  
BRUKSANVISNING**

LNT0067-001A



## FM CORDLESS HEADPHONES

# CE 0197 Ⓢ

863MHz — 865 MHz

THIS DEVICE IS INTENDED FOR USE IN THESE COUNTRIES:  
DIESES GERÄT IST FÜR DEN GEBRAUCH IN DEN FOLGENDEN LÄNDERN  
VORGESEHEN:  
DIT APPARAAT IS BEDOELD VOOR GEBRUIK IN DEZE LANDEN:  
DISPOSITIF PREVU POUR ETRE UTILISE DANS LES PAYS SUIVANTS:  
QUESTO DISPOSITIVO È DESTINATO PER L'USO IN QUESTI PAESI:  
DENNA APPARAT ÄR AVSEDD FÖR BRUK I DESSA LÄNDER:

(A) (B) (CH) (D) (DK) (FIN) (F) (I) (L) (N) (NL) (S)

|            |  |
|------------|--|
| English    | Hereby, JVC, declares that this HA-W600RF is in compliance with the essential requirements and other relevant provisions of Directive 1999/5/EC.   |
| Finnish    | JVC vakuuttaa täten että HA-W600RF tyyppinen laite on direktiivin 1999/5/EY oleellisten vaatimusten ja sitä koskevien direktiivin muiden ehtojen mukainen.   |
| Dutch      | Hierbij verklaart JVC dat het toestel HA-W600RF in overeenstemming is met de essentiële eisen en de andere relevante bepalingen van richtlijn 1999/5/EG.<br>Bij deze verklaart JVC dat deze HA-W600RF voldoet aan de essentiële eisen en aan de overige relevante bepalingen van Richtlijn 1999/5/EC.  |
| French     | Par la présente JVC déclare que l'appareil HA-W600RF est conforme aux exigences essentielles et aux autres dispositions pertinentes de la directive 1999/5/CE.<br>Par la présente, JVC déclare que ce HA-W600RF est conforme aux exigences essentielles et aux autres dispositions de la directive 1999/5/CE qui lui sont applicables.   |
| Swedish    | Härmed intygar JVC att denna HA-W600RF står i överensstämmelse med de väsentliga egenskapskrav och övriga relevanta bestämmelser som framgår av direktiv 1999/5/EG.  |
| Danish     | Undertegnede JVC erklærer herved, at følgende udstyr HA-W600RF overholder de væsentlige krav og øvrige relevante krav i direktiv 1999/5/EF.  |
| German     | Hiermit erklärt JVC, dass sich dieser/diese/dieses HA-W600RF in Übereinstimmung mit den grundlegenden Anforderungen und den anderen relevanten Vorschriften der Richtlinie 1999/5/EG befindet. (BMW)<br>Hiermit erklärt JVC die Übereinstimmung des Gerätes HA-W600RF mit den grundlegenden Anforderungen und den anderen relevanten Festlegungen der Richtlinie 1999/5/EG. (Wien) |
| Greek      | ΜΕ ΤΗΝ ΠΑΡΟΤΑ JVC ΔΗΛΩΝΕΙ ΟΤΙ Η Α-W600RF ΣΤΜΜΟΡΦΩΝΕΤΑΙ ΠΡΟΣ ΤΙΣ ΟΤΙΩΔΕΙΣ Α ΠΑΙΤΗΣΕΙΣ ΚΑΙ ΤΙΣ ΛΟΙΠΕΣ ΣΧΕΤΙΚΕΣ ΔΙΑΤΑΞΕΙ Σ ΤΗΣ ΟΔΗΓΙΑΣ 1999/5/ΕΚ.   |
| Italian    | Con la presente JVC dichiara che questo HA-W600RF è conforme ai requisiti essenziali ed alle altre disposizioni pertinenti stabilite dalla direttiva 1999/5/CE.  |
| Spanish    | Por medio de la presente JVC declara que el HA-W600RF cumple con los requisitos esenciales y cualesquiera otras disposiciones aplicables o exigibles de la Directiva 1999/5/CE.  |
| Portuguese | JVC declara que este HA-W600RF está conforme com os requisitos essenciais e outras disposições da Directiva 1999/5/CE.   |

Dear Customer,

## ENGLISH

This apparatus is in conformance with the valid European directives and standards regarding electromagnetic compatibility and electrical safety.

European representative of Victor Company of Japan, Limited is:  
JVC Technology Centre Europe GmbH  
Postfach 10 05 52  
61145 Friedberg  
Germany

Cher(e) client(e),

## FRANÇAIS

Cet appareil est conforme aux directives et normes européennes en vigueur concernant la compatibilité électromagnétique et à la sécurité électrique.

Représentant européen de la société Victor Company of Japan, Limited :  
JVC Technology Centre Europe GmbH  
Postfach 10 05 52  
61145 Friedberg  
Allemagne

Sehr geehrter Kunde,  
sehr geehrte Kundin,

## DEUTSCH

dieses Gerät stimmt mit den gültigen europäischen Richtlinien und Normen bezüglich elektromagnetischer Verträglichkeit und elektrischer Sicherheit überein.

Die europäische Vertretung für die Victor Company of Japan, Limited ist:  
JVC Technology Centre Europe GmbH  
Postfach 10 05 52  
61145 Friedberg  
Deutschland

Gentile Cliente,

## ITALIANO

Questa apparecchiatura è conforme alle direttive e alle norme europee relative alla compatibilità elettromagnetica e alla sicurezza elettrica.

Il rappresentante europeo della Victor Company of Japan, Limited è:  
JVC Technology Centre Europe GmbH  
Postfach 10 05 52  
61145 Friedberg  
Germania

Geachte klant,

## NEDERLANDS

Dit apparaat voldoet aan de geldende Europese normen en richtlijnen inzake elektromagnetische compatibiliteit en elektrische veiligheid.

De Europese vertegenwoordiger van Victor Company of Japan, Limited is:  
JVC Technology Centre Europe GmbH  
Postfach 10 05 52  
61145 Friedberg  
Duitsland

Bästa kund!

## SVENSKA

Denna apparat överensstämmer med gällande EU-direktiv och standarder beträffande elektromagnetisk kompatibilitet och elsäkerhet.

Europarepresentant för Victor Company of Japan, Limited är:  
JVC Technology Centre Europe GmbH  
Postfach 10 05 52  
61145 Friedberg  
Tyskland

## Information for Users on Disposal of Old Equipment

ENGLISH

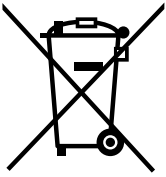

### [European Union]

This symbol indicates that the electrical and electronic equipment should not be disposed as general household waste at its end-of-life. Instead, the product should be handed over to the applicable collection point for the recycling of electrical and electronic equipment for proper treatment, recovery and recycling in accordance with your national legislation.

By disposing of this product correctly, you will help to conserve natural resources and will help prevent potential negative effects on the environment and human health which could otherwise be caused by inappropriate waste handling of this product. For more information about collection point and recycling of this product, please contact your local municipal office, your household waste disposal service or the shop where you purchased the product.

Penalties may be applicable for incorrect disposal of this waste, in accordance with national legislation.

### Attention:

This symbol is only valid in the European Union.

### (Business users)

If you wish to dispose of this product, please visit our web page [www.jvc-europe.com](http://www.jvc-europe.com) to obtain information about the take-back of the product.

### [Other Countries outside the European Union]

If you wish to dispose of this product, please do so in accordance with applicable national legislation or other rules in your country for the treatment of old electrical and electronic equipment.

## Benutzerinformationen zur Entsorgung alter Geräte

DEUTSCH

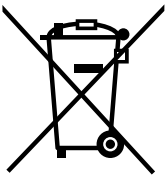

### [Europäische Union]

Dieses Symbol zeigt an, dass das elektrische bzw. elektronische Gerät nicht als normaler Haushaltsabfall entsorgt werden soll. Stattdessen sollte das Produkt zur fachgerechten Entsorgung, Weiterverwendung und Wiederverwertung in Übereinstimmung mit der Landesgesetzgebung einer entsprechenden Sammelstelle für das Recycling elektrischer und elektronischer Geräte zugeführt werden.

Die korrekte Entsorgung dieses Produkts dient dem Umweltschutz und verhindert mögliche Schäden für die Umwelt und die menschliche Gesundheit, welche durch unsachgemäße Behandlung des Produkts auftreten können. Weitere Informationen zu Sammelstellen und dem Recycling dieses Produkts erhalten Sie bei Ihrer Gemeindeverwaltung, Ihrem örtlichen Entsorgungsunternehmen oder in dem Geschäft, in dem Sie das Produkt gekauft haben.

Für die nicht fachgerechte Entsorgung dieses Abfalls können gemäß der Landesgesetzgebung Strafen ausgesprochen werden.

### Hinweis:

Dieses Symbol ist nur in der Europäischen Union gültig.

### (Geschäftskunden)

Wenn Sie dieses Produkt entsorgen möchten, besuchen Sie bitte unsere Webseite [www.jvc-europe.com](http://www.jvc-europe.com) um Informationen zur Rücknahme des Produkts zu erhalten.

### [Andere Länder außerhalb der Europäischen Union]

Wenn Sie dieses Produkt entsorgen möchten, halten Sie sich dabei bitte an die entsprechenden Landesgesetze und andere Regelungen in Ihrem Land zur Behandlung elektrischer und elektronischer Geräte.

## Informatie voor gebruikers over het weggooien van oude apparatuur

**NEDERLANDS**

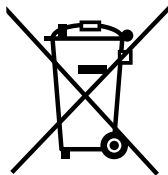

### [Europese Unie]

Deze markering geeft aan dat de elektrische en elektronische apparatuur bij het einde van de gebruiksduur niet bij het huishoudelijk afval mag worden gegooid. Het product moet in plaats daarvan worden ingeleverd bij het relevante inzamelingspunt voor hergebruik van elektrische en elektronische apparatuur, voor juiste verwerking, teruggewinning en hergebruik in overeenstemming met uw nationale wetgeving.

Door dit product naar het inzamelingspunt te brengen, werkt u mee aan het behoud van natuurlijke hulpbronnen en met het voorkomen van potentiële negatieve effecten op het milieu en de volksgezondheid, die anders veroorzaakt zouden kunnen worden door onjuiste afvalverwerking van dit product. Neem voor meer informatie over inzamelingspunten en hergebruik van dit product contact op met de gemeente in uw woonplaats, het afvalverwerkingsbedrijf of de winkel waar u het product hebt aangeschaft.

Er kunnen boetes gelden voor een onjuiste verwijdering van dit afval, in overeenstemming met de nationale wetgeving.

### (Zakelijke gebruikers)

Bezoek als u dit product wilt weggooien onze website [www.jvc-europe.com](http://www.jvc-europe.com) voor informatie over het terugnemen van het product.

### [Landen buiten de Europese Unie]

Wanneer u dit product wilt verwijderen, houdt u dan aan de geldende nationale wetgeving of andere regels in uw land voor de verwerking van oude elektrische en elektronische apparatuur.

### Let op:

Dit symbool is alleen geldig in de Europese Unie.

## Informations relatives à l'élimination des appareils usagés, à l'intention des utilisateurs

**FRANÇAIS**



### [Union européenne]

Lorsque ce symbole figure sur un appareil électrique et électronique, cela signifie qu'il ne doit pas être éliminé en tant que déchet ménager à la fin de son cycle de vie. Le produit doit être porté au point de pré-collecte approprié au recyclage des appareils électriques et électroniques pour y subir un traitement, une récupération et un recyclage, conformément à la législation nationale.

En éliminant correctement ce produit, vous contribuez à la conservation des ressources naturelles et à la prévention des éventuels effets négatifs sur l'environnement et la santé humaine, pouvant être dus à la manipulation inappropriée des déchets de ce produit. Pour plus d'informations sur le point de pré-collecte et le recyclage de ce produit, contactez votre mairie, le service d'évacuation des ordures ménagères ou le magasin dans lequel vous avez acheté le produit.

Des amendes peuvent être infligées en cas d'élimination incorrecte de ce produit, conformément à la législation nationale.

### (Utilisateurs professionnels)

Si vous souhaitez éliminer ce produit, visitez notre page Web [www.jvc-europe.com](http://www.jvc-europe.com) afin d'obtenir des informations sur sa récupération.

### [Pays ne faisant pas partie de l'Union européenne]

Si vous souhaitez éliminer ce produit, faites-le conformément à la législation nationale ou autres règles en vigueur dans votre pays pour le traitement des appareils électriques et électroniques usagés.

### Attention:

Ce symbole n'est reconnu que dans l'Union européenne.

## Informazioni per gli utenti sullo smaltimento delle apparecchiature obsolete

ITALIANO

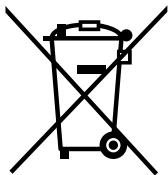

### [Unione Europea]

Questo simbolo indica che l'apparecchiatura elettrica ed elettronica a cui è relativo non deve essere smaltita tra i rifiuti domestici generici alla fine della sua vita utile. Il prodotto, invece, va consegnato a un punto di raccolta appropriato per il riciclaggio di apparecchiature elettriche ed elettroniche, per il trattamento, il recupero e il riciclaggio corretti, in conformità alle proprie normative nazionali.

Mediante lo smaltimento corretto di questo prodotto, si contribuirà a preservare le risorse naturali e a prevenire potenziali effetti negativi sull'ambiente e sulla salute umana che potrebbero essere provocati, altrimenti, da uno smaltimento inappropriato del prodotto. Per ulteriori informazioni sul punto di raccolta e il riciclaggio di questo prodotto, contattare la sede comunale locale, il servizio di smaltimento rifiuti domestici o il negozio in cui si è acquistato il prodotto.

L'utente è responsabile del conferimento dell'apparecchio a fine vita alle appropriate strutture di raccolta, pena le sanzioni previste dalla vigente legislazione sui rifiuti.

### (Per gli utenti aziendali)

Qualora si desideri smaltire questo prodotto, visitare la nostra pagina web [www.jvc-europe.com](http://www.jvc-europe.com) per ottenere informazioni sul ritiro del prodotto.

### [Per altre nazioni al di fuori dell'Unione Europea]

Qualora si desideri smaltire questo prodotto, effettuare lo smaltimento in conformità alla normativa nazionale applicabile o alle altre leggi della propria nazione relative al trattamento delle apparecchiature elettriche ed elettroniche obsolete.

**Attenzione:**  
Questo simbolo è valido solo nell'Unione Europea.

## Information till användare gällande kassering av gammal utrustning

SVENSKA

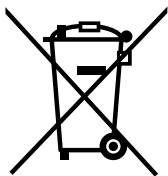

### [Europeiska gemenskapen]

Denna symbol anger att elektrisk och elektronisk utrustning inte ska kasseras som vanligt hushållsavfall, när de inte ska användas mer. Istället ska produkten lämnas in på lämplig återvinningsstation för elektrisk eller elektronisk utrustning, så att den kan tas om hand och återvinnas i enlighet med ert lands lagstiftning.

Genom att avyttra denna produkt på rätt sätt, bidrar du till att bevara naturen och förhindrar potentiellt negativa effekter på miljön och den mänskliga hälsan, som annars kan bli resultatet vid felaktig hantering av denna produkt. Kontakta ditt kommunikationskontor, det företag som hanterar dina hushållssopor eller butiken där du köpt produkten, för mer information om återvinningscentraler.

Det kan hända att du bötfälls i enlighet med ert lands lagstiftning om detta avfall kasseras på fel sätt.

### (Företagsanvändare)

Om ni vill kassera denna produkt, besök vår webbsida [www.jvc-europe.com](http://www.jvc-europe.com) för att få information om returnering av produkten.

### [Övriga länder utanför den Europeiska gemenskapen]

Om du vill kassera denna produkt, ska detta göras i enlighet med gällande lagstiftning i landet, eller enligt andra bestämmelser i ditt land, för behandling av gammal elektrisk eller elektronisk utrustning.

**Tänk på:**  
Att denna symbol endast gäller inom den Europeiska gemenskapen.

## ENGLISH

This product's performance would be degraded under a strong electro-static environment. And the function would be self-recoverable after the above case.

This product's performance would be degraded since the disturbance from the mains cord. And the function would be self-recoverable after the above case.

## DEUTSCH

Die Leistung dieses Produkts würde sich in einer stark elektrostatisch geladenen Umgebung verschlechtern. Und die Funktion würde sich nach dem obigen Fall selbst wiederherstellen.

Die Leistung dieses Produkts würde sich aufgrund einer Störung durch das Netzkabel verschlechtern. Und die Funktion würde sich nach dem obigen Fall selbst wiederherstellen.

## NEDERLANDS

De prestatie van dit product neemt af in een omgeving met een sterk elektrostatisch veld. De normale werking wordt echter automatisch hersteld wanneer de storingsbron wordt weggenomen.

De prestatie van dit product neemt af als het netsnoer storingen oppikt. De normale werking wordt echter automatisch hersteld wanneer de storingsbron wordt weggenomen.

## FRANÇAIS

Les performances de ce produit se détérioreront dans un environnement fortement électro-statique. Par ailleurs, le fonctionnement se restaurera de lui-même dans le cas ci-dessus.

Les performances de ce produit se détérioreront en cas de perturbations du cordon d'alimentation. Par ailleurs, le fonctionnement se restaurera de lui-même dans le cas ci-dessus.

## ITALIANO

La prestazione di questo prodotto potrebbe deteriorarsi in presenza di un forte ambiente elettrostatico. La funzione dovrebbe ripristinarsi automaticamente dopo il caso descritto sopra.

La prestazione di questo prodotto potrebbe deteriorarsi a causa di disturbi provenienti dal cavo di alimentazione. La funzione dovrebbe ripristinarsi automaticamente dopo il caso descritto sopra.

## SVENSKA

Denna produkts prestanda kan försämras i en starkt elektrostatisk miljö. Funktionen kan dock återställas automatiskt i ovanstående fall.

Denna produkts prestanda kan försämras på grund av störningar från nätkabeln. Funktionen kan dock återställas automatiskt i ovanstående fall.

### Per l'Italia:

“Si dichiara che il questo prodotto di marca JVC è conforme alle prescrizioni del Decreto Ministeriale n.548 del 28/08/95 pubblicato sulla Gazzetta Ufficiale della Repubblica Italiana n.301 del 28/12/95.”

## **“SOME DO’S AND DON’TS ON THE SAFE USE OF EQUIPMENT”**

This equipment has been designed and manufactured to meet international safety standards but, like any electrical apparatus, care must be taken if you are to obtain the best results and safety is to be assured.

.....

Do read the operating instructions before you attempt to use the equipment.

Do ensure that all electrical connections (including the plug, extension cord and inter-connections between pieces of equipment) are properly made and in accordance with the manufacturer’s instructions. Switch off and withdraw the plug when making or changing connections.

Do consult your dealer if you are ever in doubt about the installation or operation or safety of your equipment.

Do be careful with glass panels or doors on equipment.

.....

**DON’T** continue to operate the equipment if you are in any doubt about it working normally, or if it is damaged in any way—switch off—withdraw the plug and consult your dealer.

**DON’T** remove any fixed cover as this may expose dangerous voltages.

**DON’T** leave equipment switched on when it is unattended unless it is specifically stated that it is designed for unattended operation or has a standby mode.

Switch off using the switch on the equipment and make sure that your family know how to do this.

Special arrangements may need to be made for infirm or handicapped people.

**DON’T** use equipment such as personal stereos or radios so that you are distracted from the requirements of road safety. It is illegal to watch television when driving.

**DON’T** listen to headphones at high volume as such use can permanently damage your hearing.

**DON’T** obstruct the ventilation of the equipment, for example with curtains or on soft furnishings.

Overheating will cause damage and shorten the life of the equipment.

**DON’T** use makeshift stands and **NEVER** fix legs with wood screws. To ensure complete safety always fit the manufacturer’s approved stand or legs with the fixing screws supplied according to the instructions.

**DON’T** allow electrical equipment to be exposed to rain or moisture.

**ABOVE ALL**

**NEVER** let anyone especially children push anything into holes, slots or any other opening in the case. This could result in a fatal electrical shock.

**NEVER** guess or make changes with electrical equipment of any kind. It is better to be safe than sorry!

Thank you for purchasing a JVC product.  
Please read all instructions carefully before operation, to ensure your complete understanding and to obtain the best possible performance from the unit.

## FEATURES

- Reception range up to 100 m (using JVC measurement system)
- Auto Tuning–Headphones automatically tunes in to the base station (transmitter) as it turns on
- On Stand Charging–Rechargeable system with the exclusive Ni-MH battery that requires no charge cable
- Auto Power On/Off transmitter
- “PLL” Stabilized Transmission Technology
- Auto-level control circuit that automatically adjusts signals to the appropriate modulation level
- Large 40 mm dia. driver unit for high quality sound
- Adaptable to any audio/visual equipment which has the analog audio output.

## **Contents**

|                                   |           |
|-----------------------------------|-----------|
| <b>Precautions .....</b>          | <b>2</b>  |
| <b>Parts identification.....</b>  | <b>3</b>  |
| <b>Connection.....</b>            | <b>4</b>  |
| <b>Battery installation .....</b> | <b>5</b>  |
| <b>Charging the battery.....</b>  | <b>6</b>  |
| <b>Basic operations .....</b>     | <b>7</b>  |
| <b>Troubleshooting.....</b>       | <b>9</b>  |
| <b>Specifications .....</b>       | <b>10</b> |

### **For your health and traffic safety**

- Be careful not to turn the sound volume up too high when using the headphones. Your hearing can be damaged by listening to sounds at excessive volume for long periods.
- Never use the headphones when driving a car, motorcycle, or bicycle. This could result in an accident.
- Pay close attention to traffic around you when using the headphones while walking. Not doing so could result in an accident.



# Precautions

## Important cautions

### CAUTION

To reduce the risk of electrical shocks, fire, etc.:

1. Do not remove screws, cover or cabinet.
2. Do not expose this appliance to rain or moisture.

## Precautions

### Installation

- Select a place which is level, dry and neither too hot nor too cold (between 0°C and 35°C).
- Keep away from direct sunlight.
- Do not put it too close to a heater.
- Indoor use only.

### Power cord

- Do not handle the power cord with wet hands!
- Do not bend the power cord sharply.
- Do not connect the supplied AC adaptor to any other equipment. It is exclusively for use with this unit.

### Malfunctions, etc.

- There are no serviceable parts inside. If anything goes wrong, unplug the power cord and consult your dealer.
- Do not insert any metallic object.
- Do not allow water to get inside.
- Do not move or bend the ear cups or any other part of the headphones with excessive force. It may damage the headphones.
- Stop using the headphones if they are causing discomfort on your skin. Otherwise inflammation or irritation may be caused on your skin.
- The ear pad will wear out earlier than the other parts even in normal use or in normal keeping due to the material characteristics. For replacement of the ear pads, please consult with the dealer where you purchased the headphones.
- If the headphone is not used for a prolonged time, unplug the AC adaptor from an AC outlet.

## Battery precautions

- Be sure to use the supplied exclusive battery. Do not use any other rechargeable or dry cell battery.
- Use only the type of battery the manufacturer recommends when replacing the battery.
- Do not throw the battery in a fire or heat it.
- Do not immerse or wet the battery in water.
- Do not remove or damage the covering tube.
- Do not subject the battery to strong shocks or throw it.
- If any liquid from the battery gets into your eyes, it may cause blindness. If battery liquid does get into your eyes, do not rub them, but instead immediately wash them thoroughly with clean water, then consult a doctor at once. Also, should any liquid from the rechargeable battery get onto your skin or clothes, it may burn your skin. In this case, wash with clean water immediately.
- When discarding batteries, environmental problems must be considered and the local rules or laws governing the disposal of these batteries must be followed strictly.

## Charging precautions

- Charge only with supplied Ni-MH type battery. Other types of battery may burst causing personal injury and damage.
- Use only the supplied base station to charge the battery.
- Be sure to use the supplied AC adaptor.

## Supplied accessories

Check to be sure you have all of the supplied accessories.

The number in parentheses is the quantity of the pieces supplied. If anything is missing, contact your dealer immediately.

- Exclusive rechargeable batteries (2)
- Exclusive AC adaptor (1)
- Connection cord (1)
- Conversion cord (1)
- Plug adaptor (1)

# Parts identification

See pages in parentheses for details.

## Base station (transmitter and battery charging unit)

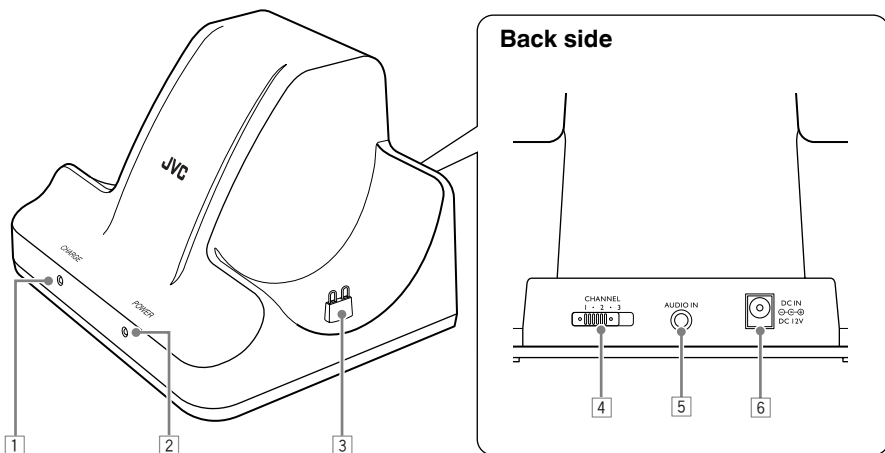

- 1 CHARGE indicator (6)
- 2 POWER indicator (7)
- 3 Battery charging terminal (6)

- 4 CHANNEL selector (8)
- 5 AUDIO IN jack (4)
- 6 DC IN  $\ominus$   $\oplus$  jack (4)

## Headphones

Left

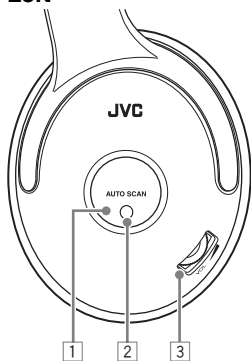

- 1 AUTO SCAN button (7, 8)
- 2 AUTO SCAN indicator (7)
- 3 VOL (volume) (7)
- 4 Ear pad (5)
- 5 Battery charging terminal (6)
- 6 POWER button (6, 7)
- 7 POWER indicator (6, 7)

Right

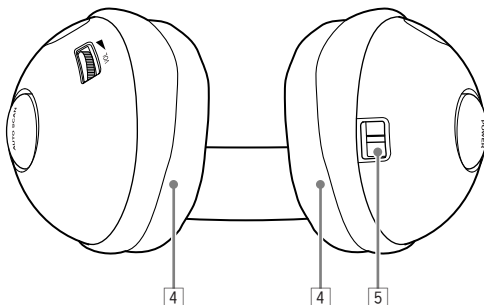
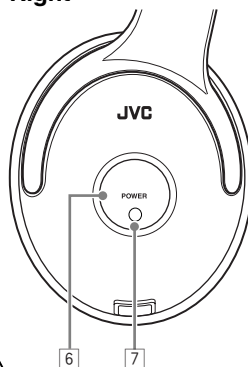

# Connection

**Be sure to connect the AC adaptor after all other connections are complete.**

- 1** Connect the base station to the AV equipment.
- 2** Connect the AC adaptor to the base station.
- 3** Connect the AC adaptor to the AC outlet.

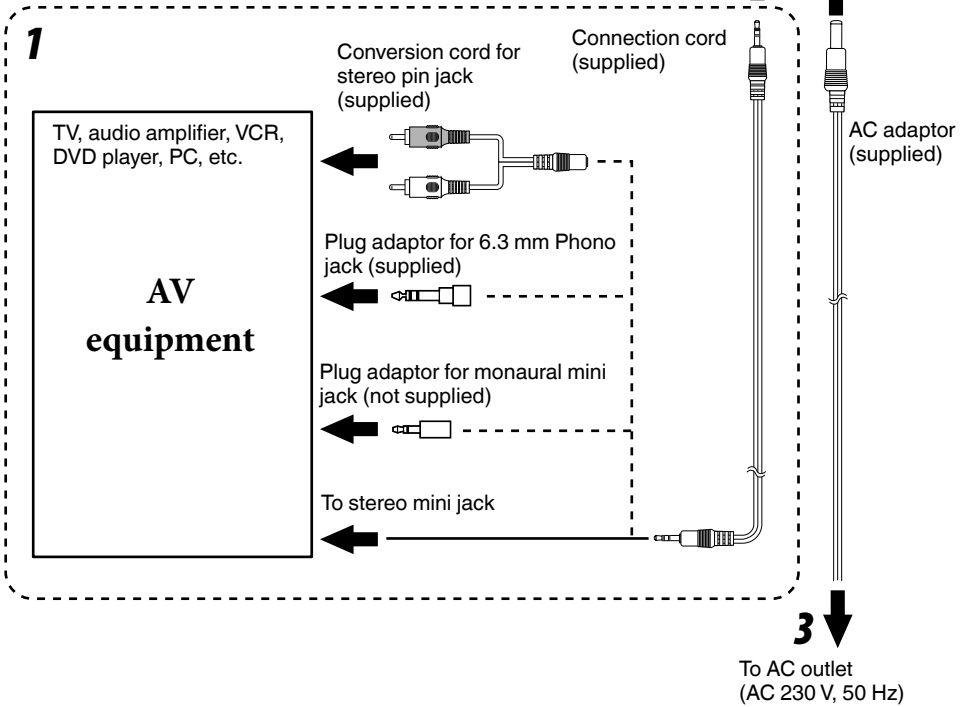
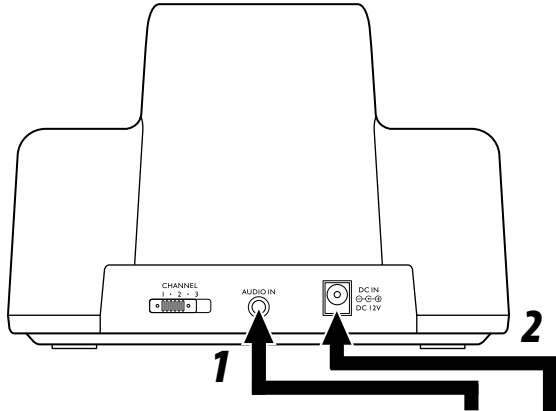

**Note:**  
Do not use any other AC adaptor than the supplied AC adaptor. Otherwise, malfunctions may be caused.

# Battery installation

- 1** Take off the ear pad of the right headphone.

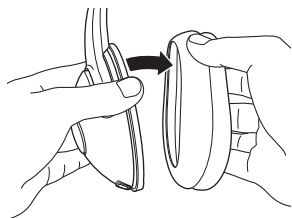

- 2** Take off the battery covers.

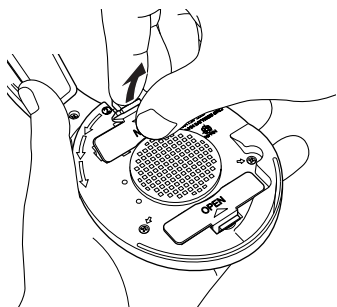

- 3** Install the batteries.

Match the polarity (+ and -) on the batteries with the + and - marking on the battery compartments.

- Insert the - terminal of the battery at first.

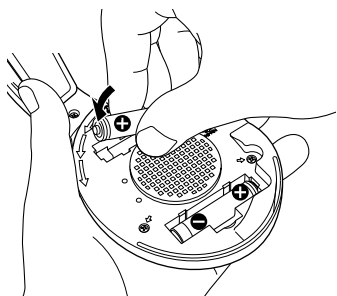

Be sure to use the supplied exclusive battery. Do not use any other rechargeable or dry cell battery, which may cause malfunctions or damage the unit.

- 4** Put on the battery covers.

- 5** Put on the ear pad.

- 1** Insert the hem of the ear pad into the slit on the headphone.

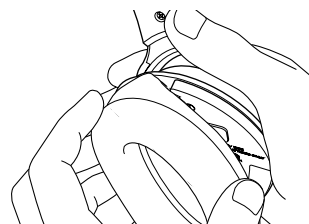
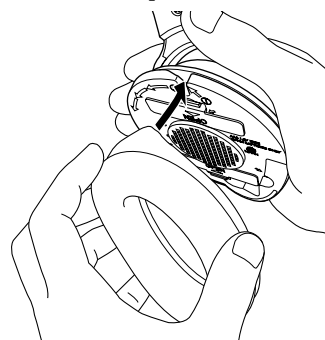

- 2** Turn the ear pad anticlockwise to slide all the hem into the groove on the headphone.

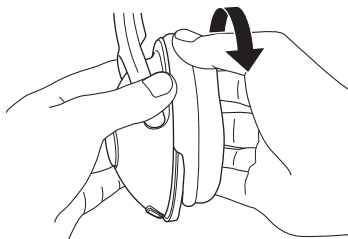
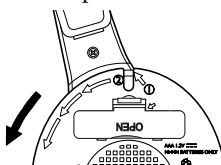

- Be sure that all the hem is inserted fully. If not, turn the ear pad anticlockwise again until all the hem slides in.

# Charging the battery

The base station works as the battery charging unit. Charge the rechargeable battery before starting to use the headphones.

You can continuously use the headphones for about 10 hours after full battery charge.

## 1 Make sure that the headphones are turned off.

You cannot charge the battery of the headphones when the headphones are turned on. Press **POWER** to turn the Power indicator off.

## 2 Put on the headphones on the base station so that their charging terminals contact firmly.

When putting the headphones on the base station, hold them and adjust their position with your both hands to assure the contact of the terminals.

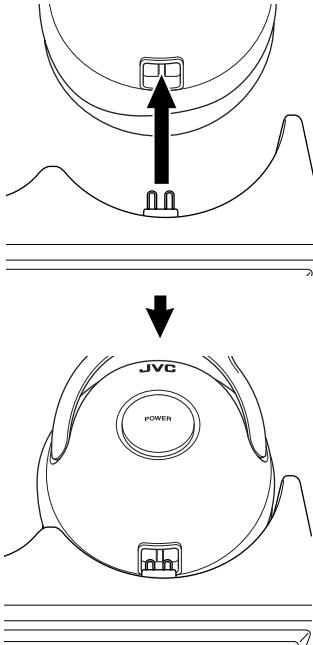

## 3 Confirm the CHARGE indicator lights up.

If the charge indicator does not light up, return steps **1** and **2** after checking the connection of the AC adaptor.

- It takes about 30 hours to charge the batteries fully.
- 30-hour charging may not charge the battery fully depending on the battery or other conditions.
- The cycle life of the rechargeable battery is approximately 500 times. (It varies depending on the conditions when charging.)
- The battery leaks its charge little by little even when the headphones' power is off, due to its characteristics.

### Notes on the battery and charging

- To make battery life longer:
    - charging the battery within the temperature range of 10°C – 35°C.
    - not using the headphones in excessively cold places. Low temperature decreases battery life.
    - charging the battery after its complete discharging. Charging before complete discharge makes the battery life gradually shorter.
  - Replace the batteries when their lives become about half or the playback sound become constantly noisy.
- Use the exclusive rechargeable Ni-MH battery J47958 only.** When purchasing the battery, consult the dealer where you bought the product.
- Replace two batteries at the same time when replacing.

# Basic operations

## Listening to the sound from the base station

The base station works as the FM transmitter and send sound to the headphones.

### Precaution

Turn down the volume of the headphones with the VOL dial before turning on its power to avoid excessive volume.

## 1 Start playback on the AV equipment connected with the base station.

The base station turns on automatically and starts to transmit FM signals (Auto Power On function).

The POWER indicator of the base station lights up.

- In some situations, the power may not be turned on automatically by the input sound (e. g. a song with a quiet opening or fade in). This is not a malfunction.

## 2 Press POWER on the headphones to turn on the power.



The POWER indicator lights up and the headphones automatically starts to tune in to the signal from the base station (Auto Tuning function).

The AUTO SCAN indicator lights up when tuned in.

- **Press the center of the button firmly when pressing POWER. Pressing the edge may not turn on the power.**
- Charge the battery in the following cases.  
The battery ran out:
  - The POWER indicator does not light up after pressing POWER.
  - The AUTO SCAN indicator does not light up though the POWER indicator lights up.

- No sound is heard while Auto Tuning. It takes a few seconds to tune in.
- Press AUTO SCAN when the sound does not come out properly.



## 3 Adjust the volumes of the AV equipment and the headphones.



- Adjust the volumes within the area about 7 m from the base station to get optimum signal reception.
- You can get better sound by setting the volume of the AV equipment as high as possible without causing distortion and that of the headphone lower (except when connecting the AV equipment through LINE OUT jacks).

### To Turn off the units

Press POWER on the headphones and stop playback on the AV equipment. The headphones' POWER indicator goes off.



- The base station automatically turns off if no signals come in for about four minutes (Auto Power OFF function).
- The white noise may come out when the base station turns off. Take off and turns off the headphones after using.

# Basic operations

## Selecting a better reception channel

When the playback sound is noisy, you can choose one of the other two channels to transmit signals on the base station.

- The white noise may come out when switching the channel. Take off the headphones when switching the channel.

**1** Slide the **CHANNEL** selector on the back side of the base station to select another channel.



**2** Press **AUTO SCAN** on the headphones to tune in to the new channel.



**3** Repeat Steps 1 and 2 to select the best channel.

### Listening area

The headphones can receive the FM signal of the base station 100 m away from it at maximum (when no interference or obstacles exist between them). But the receivable range becomes shorter or reception quality becomes poorer in the following cases:

- In places such as reinforced concrete buildings
- Obstacles such as steel-reinforced doors exist between the base station and headphones
- Items such as metal furniture are situated nearby
- In places facing a street
- Noise or interference sources exist nearby (e.g. mobile ham, radio stations, high-voltage power lines, a microwave oven, cordless phones, cellular phones, etc.)

# Troubleshooting

What appears to be trouble is not always serious. Check the following points before calling a service center.

| Symptom                            | Cause/Remedy   |
|------------------------------------|--|
| No sound comes out at all.         | <ul style="list-style-type: none"><li>• Turns on the power of the headphones.</li><li>• Start playback on the AV equipment connected to the base station.</li><li>• Check the connection between the base station and the AV equipment.</li><li>• Turns up the volume of the headphones or the connected AV equipment to an appropriate level.</li><li>• Fully charge the headphones' battery.</li></ul>   |
| No sound comes out from R-channel. | <ul style="list-style-type: none"><li>• Check the connection between the base station and the AV equipment.</li><li>• Sound comes out only of L-channel when the base station is connected to the monaural audio output. Convert the mini plug to the base station from stereo to monaural with the plug adaptor (not supplied).</li></ul>   |
| Sound is distorted.                | <ul style="list-style-type: none"><li>• The headphones' battery will soon run out. Fully charge the battery.</li><li>• The volume of the headphones and/or the connected AV equipment is too high. Adjust their volume to an appropriate level.</li></ul>  |
| Sound is noisy.                    | <ul style="list-style-type: none"><li>• The headphones' battery will soon run out. Fully charge the battery.</li><li>• Switch the base station channel to another and press AUTO SCAN on the headphones.</li><li>• The volume of the connected AV equipment is too low. Adjust the volume as high as possible without causing distortion.</li><li>• Too far from the base station. Use the headphones within the range of the base station (see page 8).</li></ul> |
| Cannot charge the battery.         | <ul style="list-style-type: none"><li>• Check the contact of the charging terminals on the base station and the headphones.</li><li>• Check the polarity of the battery.</li><li>• The cycle life of the battery ended. Replace with the new battery (see page 6).</li></ul>   |



# Specifications

## General Specifications

|                                  |   |
|----------------------------------|---|
| Modulation system:               | Stereo frequency modulation system  |
| Carrier frequency:               | 863.5 MHz (Channel 1)<br>864.0 MHz (Channel 2)<br>864.5 MHz (Channel 3)         |
| Usable area (distance to reach): | Max. 100 m (using JVC measurement systems, under controlled ambient conditions) |
| Frequency response:              | 25 Hz – 13,000 Hz   |
| Distortion:                      | Less than 3% (at 1 kHz)   |

## Transmitter (J22321-001)

|                        |  |
|------------------------|--|
| Power requirements:    | DC 12 V (with the exclusive AC adaptor)        |
| Audio input terminals: | 3.5 mm dia. stereo mini jack                   |
| Input impedance:       | 36 k $\Omega$                                  |
| Reference input level: | 350 mV   |
| Dimensions:            | 159 (W) mm x 114 (D) mm x 123 (H) mm           |
| Mass:                  | 280 g (without connection cord and AC adaptor) |

## Headphones

|                       |  |
|-----------------------|--|
| Power requirements:   | Rechargeable Ni-MH battery (1.2 V) x 2 |
| Battery running time: | 10 hours (when charged for 30 hours)   |
| Mass:                 | 250 g (with rechargeable battery)      |

## Supplied Accessories

- Instructions x 1
- Exclusive AC adaptor x 1 (J34676-001: AC 230 V, 50 Hz, 7 W)
- Exclusive rechargeable Ni-MH battery x 2
- Connection cord x 1 (3.5 mm dia. stereo mini plug: 2.2 m)
- Conversion cord x 1 (3.5 mm dia. stereo mini jack — RCA pin plug x 2: 0.1 m)
- Plug adaptor x 1 (converts 3.5 mm dia. stereo mini plug to a 6.3 mm dia. standard stereo phone plug)

\* Design and specifications subject to change without notice.



HA-W600RF-G

F.M. CORDLESS HEADPHONES

**JVC**

# JVC



FM CORDLESS HEADPHONES

---

# HA-W600RF-B



**INSTRUCTIONS**

LNT0068-001A

**FM CORDLESS HEADPHONES****CE 0197** **863MHz — 865 MHz**

THIS DEVICE IS INTENDED FOR USE IN THESE COUNTRIES:



|            |  |
|------------|--|
| English    | Hereby, JVC, declares that this HA-W600RF is in compliance with the essential requirements and other relevant provisions of Directive 1999/5/EC.   |
| Finnish    | JVC vakuuttaa täten että HA-W600RF tyyppinen laite on direktiivin 1999/5/EY oleellisten vaatimusten ja sitä koskevien direktiivin muiden ehtojen mukainen.   |
| Dutch      | Hierbij verklaart JVC dat het toestel HA-W600RF in overeenstemming is met de essentiële eisen en de andere relevante bepalingen van richtlijn 1999/5/EG.   |
|            | Bij deze verklaart JVC dat deze HA-W600RF voldoet aan de essentiële eisen en aan de overige relevante bepalingen van Richtlijn 1999/5/EC.  |
| French     | Par la présente JVC déclare que l'appareil HA-W600RF est conforme aux exigences essentielles et aux autres dispositions pertinentes de la directive 1999/5/CE.   |
|            | Par la présente, JVC déclare que ce HA-W600RF est conforme aux exigences essentielles et aux autres dispositions de la directive 1999/5/CE qui lui sont applicables.                                   |
| Swedish    | Härmed intygar JVC att denna HA-W600RF står i överensstämmelse med de väsentliga egenskapskrav och övriga relevanta bestämmelser som framgår av direktiv 1999/5/EG.                                    |
| Danish     | Undertegnede JVC erklærer herved, at følgende udstyr HA-W600RF overholder de væsentlige krav og øvrige relevante krav i direktiv 1999/5/EF.  |
| German     | Hiermit erklärt JVC, dass sich dieser/diese/dieses HA-W600RF in Übereinstimmung mit den grundlegenden Anforderungen und den anderen relevanten Vorschriften der Richtlinie 1999/5/EG befindet. (BMW i) |
|            | Hiermit erklärt JVC die Übereinstimmung des Gerätes HA-W600RF mit den grundlegenden Anforderungen und den anderen relevanten Festlegungen der Richtlinie 1999/5/EG. (Wien)                             |
| Greek      | ΜΕ ΤΗΝ ΠΑΡΟΥΣΑ JVC ΔΗΛΩΝΕΙ ΟΤΙ Η Α-W600RF ΣΤΗΜΜΟΡΦΩΝΕΤΑΙ ΠΡΟΣ ΤΙΣ ΟΤΣΙΩΔΕΙΣ Α ΠΑΙΤΗΣΕΙΣ ΚΑΙ ΤΙΣ ΛΟΙΠΕΣ ΣΧΕΤΙΚΕΣ ΔΙΑΤΑΞΕΙ Σ ΤΗΣ ΟΔΗΓΙΑΣ 1999/5/ΕΚ.  |
| Italian    | Con la presente JVC dichiara che questo HA-W600RF è conforme ai requisiti essenziali ed alle altre disposizioni pertinenti stabilite dalla direttiva 1999/5/CE.  |
| Spanish    | Por medio de la presente JVC declara que el HA-W600RF cumple con los requisitos esenciales y cualesquiera otras disposiciones aplicables o exigibles de la Directiva 1999/5/CE.                        |
| Portuguese | JVC declara que este HA-W600RF está conforme com os requisitos essenciais e outras disposições da Directiva 1999/5/CE.   |

Dear Customer,

This apparatus is in conformance with the valid European directives and standards regarding electromagnetic compatibility and electrical safety.

European representative of Victor Company of Japan, Limited is:

JVC Technology Centre Europe GmbH

Postfach 10 05 52

61145 Friedberg

Germany

## Information for Users on Disposal of Old Equipment

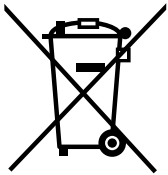

### [European Union]

This symbol indicates that the electrical and electronic equipment should not be disposed as general household waste at its end-of-life. Instead, the product should be handed over to the applicable collection point for the recycling of electrical and electronic equipment for proper treatment, recovery and recycling in accordance with your national legislation.

By disposing of this product correctly, you will help to conserve natural resources and will help prevent potential negative effects on the environment and human health which could otherwise be caused by inappropriate waste handling of this product. For more information about collection point and recycling of this product, please contact your local municipal office, your household waste disposal service or the shop where you purchased the product.

Penalties may be applicable for incorrect disposal of this waste, in accordance with national legislation.

### (Business users)

If you wish to dispose of this product, please visit our web page [www.jvc-europe.com](http://www.jvc-europe.com) to obtain information about the take-back of the product.

### [Other Countries outside the European Union]

If you wish to dispose of this product, please do so in accordance with applicable national legislation or other rules in your country for the treatment of old electrical and electronic equipment.

### Attention:

This symbol is only valid in the European Union.

---

This product's performance would be degraded under a strong electro-static environment. And the function would be self-recoverable after the above case.  
This product's performance would be degraded since the disturbance from the mains cord. And the function would be self-recoverable after the above case.

## **“SOME DO’S AND DON’TS ON THE SAFE USE OF EQUIPMENT”**

This equipment has been designed and manufactured to meet international safety standards but, like any electrical apparatus, care must be taken if you are to obtain the best results and safety is to be assured.



Do read the operating instructions before you attempt to use the equipment.

Do ensure that all electrical connections (including the plug, extension cord and inter-connections between pieces of equipment) are properly made and in accordance with the manufacturer’s instructions. Switch off and withdraw the plug when making or changing connections.

Do consult your dealer if you are ever in doubt about the installation or operation or safety of your equipment.

Do be careful with glass panels or doors on equipment.



**DON’T** continue to operate the equipment if you are in any doubt about it working normally, or if it is damaged in any way—switch off—withdraw the plug and consult your dealer.

**DON’T** remove any fixed cover as this may expose dangerous voltages.

**DON’T** leave equipment switched on when it is unattended unless it is specifically stated that it is designed for unattended operation or has a standby mode.

Switch off using the switch on the equipment and make sure that your family know how to do this.

Special arrangements may need to be made for infirm or handicapped people.

**DON’T** use equipment such as personal stereos or radios so that you are distracted from the requirements of road safety. It is illegal to watch television when driving.

**DON’T** listen to headphones at high volume as such use can permanently damage your hearing.

**DON’T** obstruct the ventilation of the equipment, for example with curtains or on soft furnishings.

Overheating will cause damage and shorten the life of the equipment.

**DON’T** use makeshift stands and **NEVER** fix legs with wood screws. To ensure complete safety always fit the manufacturer’s approved stand or legs with the fixing screws supplied according to the instructions.

**DON’T** allow electrical equipment to be exposed to rain or moisture.

**ABOVE ALL**

**NEVER** let anyone especially children push anything into holes, slots or any other opening in the case. This could result in a fatal electrical shock.

**NEVER** guess or make changes with electrical equipment of any kind. It is better to be safe than sorry!

Thank you for purchasing a JVC product.

Please read all instructions carefully before operation, to ensure your complete understanding and to obtain the best possible performance from the unit.

## FEATURES

- Reception range up to 100 m (using JVC measurement system)
- Auto Tuning–Headphones automatically tunes in to the base station (transmitter) as it turns on
- On Stand Charging–Rechargeable system with the exclusive Ni-MH battery that requires no charge cable
- Auto Power On/Off transmitter
- “PLL” Stabilized Transmission Technology
- Auto-level control circuit that automatically adjusts signals to the appropriate modulation level
- Large 40 mm dia. driver unit for high quality sound
- Adaptable to any audio/visual equipment which has the analog audio output.

## ***Contents***

|                                   |           |
|-----------------------------------|-----------|
| <b>Precautions .....</b>          | <b>2</b>  |
| <b>Parts identification.....</b>  | <b>3</b>  |
| <b>Connection.....</b>            | <b>4</b>  |
| <b>Battery installation .....</b> | <b>5</b>  |
| <b>Charging the battery.....</b>  | <b>6</b>  |
| <b>Basic operations .....</b>     | <b>7</b>  |
| <b>Troubleshooting.....</b>       | <b>9</b>  |
| <b>Specifications .....</b>       | <b>10</b> |

### **For your health and traffic safety**

- Be careful not to turn the sound volume up too high when using the headphones. Your hearing can be damaged by listening to sounds at excessive volume for long periods.
- Never use the headphones when driving a car, motorcycle, or bicycle. This could result in an accident.
- Pay close attention to traffic around you when using the headphones while walking. Not doing so could result in an accident.

# Precautions

---

## Important cautions

---

---

### CAUTION

To reduce the risk of electrical shocks, fire, etc.:

1. Do not remove screws, cover or cabinet.
2. Do not expose this appliance to rain or moisture.

## Precautions

### Installation

- Select a place which is level, dry and neither too hot nor too cold (between 0°C and 35°C).
- Keep away from direct sunlight.
- Do not put it too close to a heater.
- Indoor use only.

### Power cord

- Do not handle the power cord with wet hands!
- Do not bend the power cord sharply.
- Do not connect the supplied AC adaptor to any other equipment. It is exclusively for use with this unit.

### Malfunctions, etc.

- There are no serviceable parts inside. If anything goes wrong, unplug the power cord and consult your dealer.
- Do not insert any metallic object.
- Do not allow water to get inside.
- Do not move or bend the ear cups or any other part of the headphones with excessive force. It may damage the headphones.
- Stop using the headphones if they are causing discomfort on your skin. Otherwise inflammation or irritation may be caused on your skin.
- The ear pad will wear out earlier than the other parts even in normal use or in normal keeping due to the material characteristics. For replacement of the ear pads, please consult with the dealer where you purchased the headphones.
- If the headphone is not used for a prolonged time, unplug the AC adaptor from an AC outlet.

## Battery precautions

- Be sure to use the supplied exclusive battery. Do not use any other rechargeable or dry cell battery.
- Use only the type of battery the manufacturer recommends when replacing the battery.
- Do not throw the battery in a fire or heat it.
- Do not immerse or wet the battery in water.
- Do not remove or damage the covering tube.
- Do not subject the battery to strong shocks or throw it.
- If any liquid from the battery gets into your eyes, it may cause blindness. If battery liquid does get into your eyes, do not rub them, but instead immediately wash them thoroughly with clean water, then consult a doctor at once. Also, should any liquid from the rechargeable battery get onto your skin or clothes, it may burn your skin. In this case, wash with clean water immediately.
- When discarding batteries, environmental problems must be considered and the local rules or laws governing the disposal of these batteries must be followed strictly.

## Charging precautions

- Charge only with supplied Ni-MH type battery. Other types of battery may burst causing personal injury and damage.
- Use only the supplied base station to charge the battery.
- Be sure to use the supplied AC adaptor.

## Supplied accessories

---

---

Check to be sure you have all of the supplied accessories.

The number in parentheses is the quantity of the pieces supplied. If anything is missing, contact your dealer immediately.

- Exclusive rechargeable batteries (2)
- Exclusive AC adaptor (1)
- Connection cord (1)
- Conversion cord (1)
- Plug adaptor (1)



# Parts identification

See pages in parentheses for details.

## Base station (transmitter and battery charging unit)

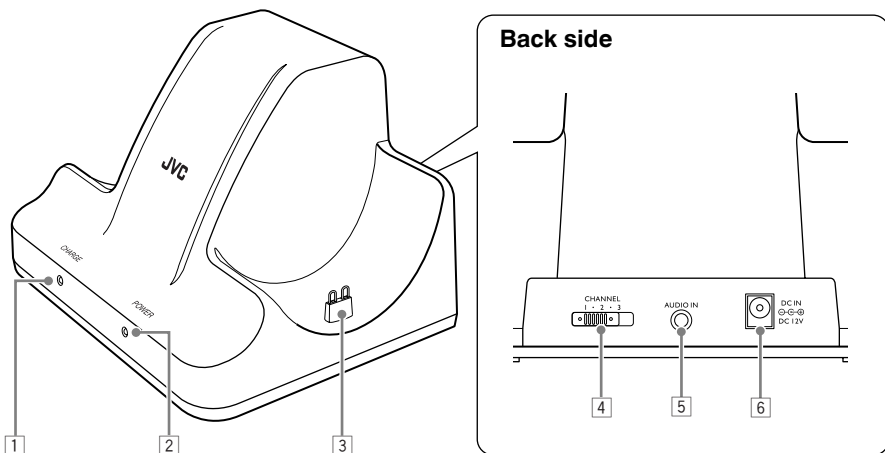

- 1 CHARGE indicator (6)
- 2 POWER indicator (7)
- 3 Battery charging terminal (6)

- 4 CHANNEL selector (8)
- 5 AUDIO IN jack (4)
- 6 DC IN  $\ominus$   $\oplus$  jack (4)

## Headphones

Left

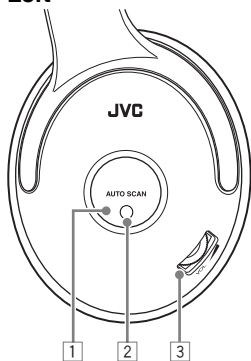

- 1 AUTO SCAN button (7, 8)
- 2 AUTO SCAN indicator (7)
- 3 VOL (volume) (7)
- 4 Ear pad (5)
- 5 Battery charging terminal (6)
- 6 POWER button (6, 7)
- 7 POWER indicator (6, 7)

Right

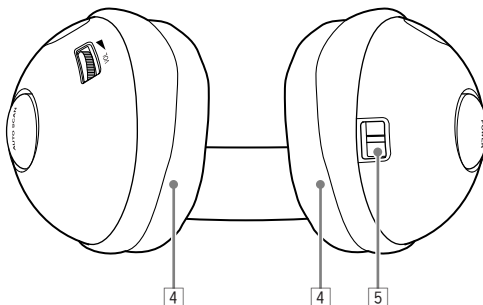
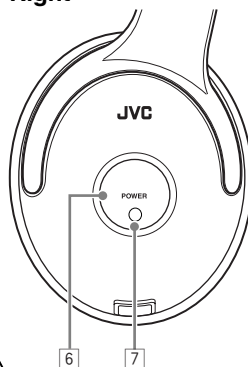

# Connection

**Be sure to connect the AC adaptor after all other connections are complete.**

- 1** Connect the base station to the AV equipment.
- 2** Connect the AC adaptor to the base station.
- 3** Connect the AC adaptor to the AC outlet.

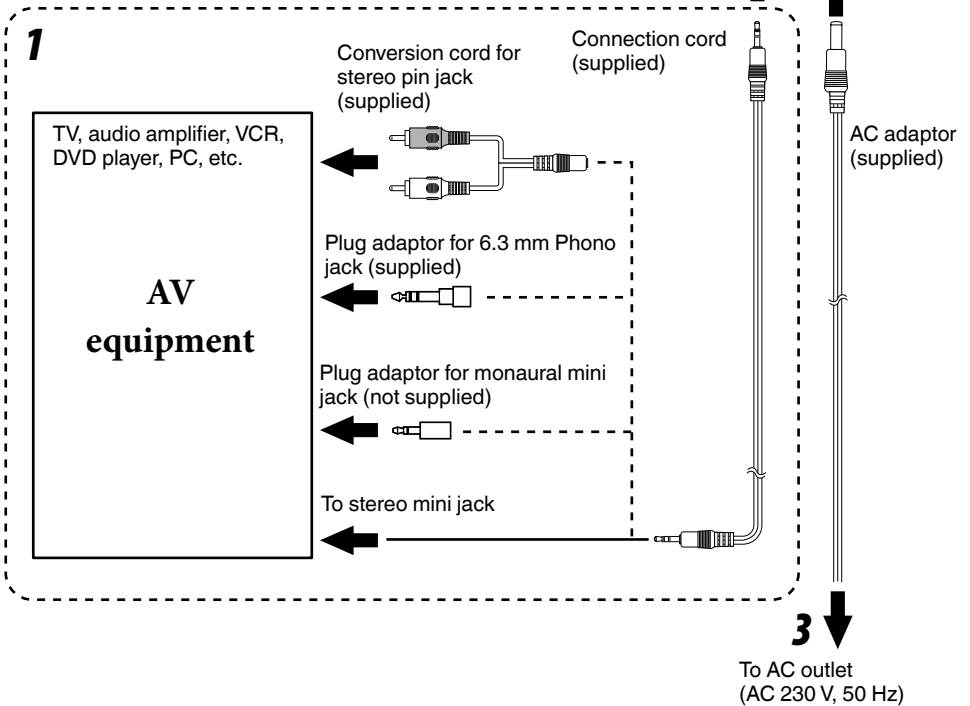
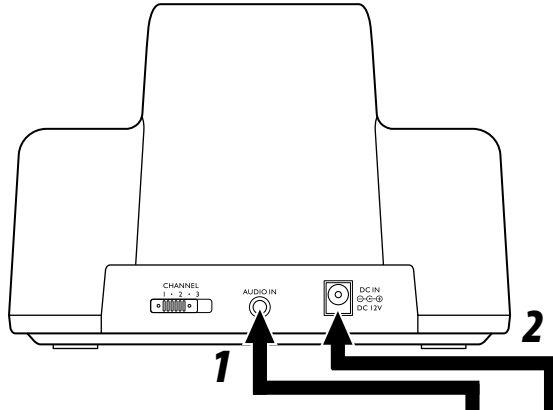

**Note:**  
Do not use any other AC adaptor than the supplied AC adaptor. Otherwise, malfunctions may be caused.

# Battery installation

- 1** Take off the ear pad of the right headphone.

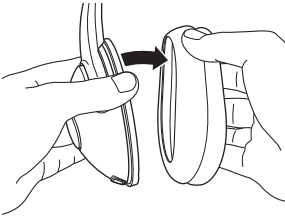

- 2** Take off the battery covers.

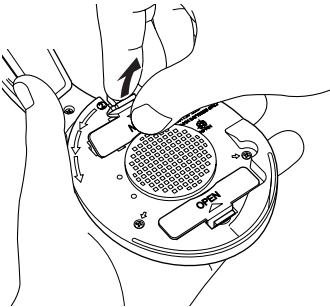

- 3** Install the batteries.

Match the polarity (+ and -) on the batteries with the + and - marking on the battery compartments.

- Insert the - terminal of the battery at first.

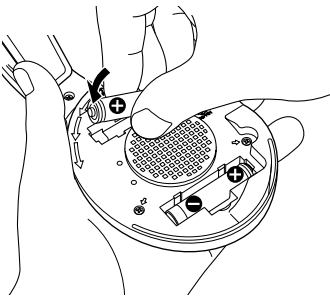

Be sure to use the supplied exclusive battery. Do not use any other rechargeable or dry cell battery, which may cause malfunctions or damage the unit.

- 4** Put on the battery covers.

- 5** Put on the ear pad.

- 1** Insert the hem of the ear pad into the slit on the headphone.

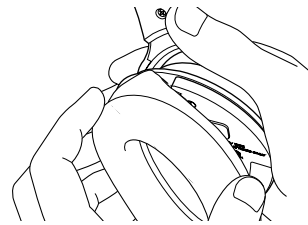
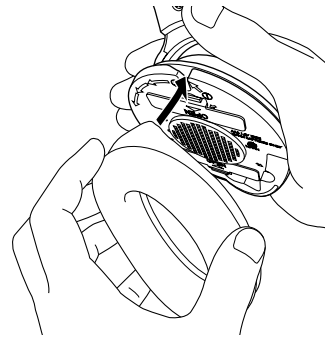

- 2** Turn the ear pad anticlockwise to slide all the hem into the groove on the headphone.

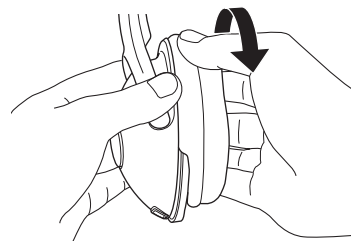
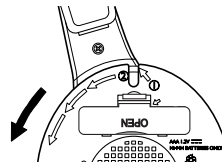

- Be sure that all the hem is inserted fully. If not, turn the ear pad anticlockwise again until all the hem slides in.

# Charging the battery

The base station works as the battery charging unit. Charge the rechargeable battery before starting to use the headphones.

You can continuously use the headphones for about 10 hours after full battery charge.

## 1 Make sure that the headphones are turned off.

You cannot charge the battery of the headphones when the headphones are turned on. Press **POWER** to turn the Power indicator off.

## 2 Put on the headphones on the base station so that their charging terminals contact firmly.

When putting the headphones on the base station, hold them and adjust their position with your both hands to assure the contact of the terminals.

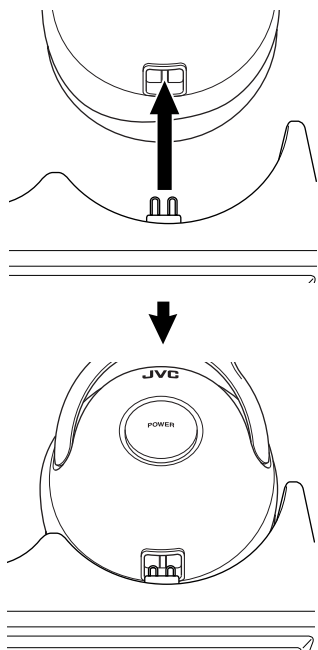

## 3 Confirm the CHARGE indicator lights up.

If the charge indicator does not light up, return steps **1** and **2** after checking the connection of the AC adaptor.

- It takes about 30 hours to charge the batteries fully.
- 30-hour charging may not charge the battery fully depending on the battery or other conditions.
- The cycle life of the rechargeable battery is approximately 500 times. (It varies depending on the conditions when charging.)
- The battery leaks its charge little by little even when the headphones' power is off, due to its characteristics.

### Notes on the battery and charging

- To make battery life longer:
  - charging the battery within the temperature range of 10°C – 35°C.
  - not using the headphones in excessively cold places. Low temperature decreases battery life.
  - charging the battery after its complete discharging. Charging before complete discharge makes the battery life gradually shorter.
- Replace the batteries when their lives become about half or the playback sound become constantly noisy.  
**Use the exclusive rechargeable Ni-MH battery J47958 only.** When purchasing the battery, consult the dealer where you bought the product.
- Replace two batteries at the same time when replacing.

# Basic operations

## Listening to the sound from the base station

The base station works as the FM transmitter and send sound to the headphones.

### Precaution

Turn down the volume of the headphones with the VOL dial before turning on its power to avoid excessive volume.

## 1 Start playback on the AV equipment connected with the base station.

The base station turns on automatically and starts to transmit FM signals (Auto Power On function).

The POWER indicator of the base station lights up.

- In some situations, the power may not be turned on automatically by the input sound (e. g. a song with a quiet opening or fade in). This is not a malfunction.

## 2 Press POWER on the headphones to turn on the power.



The POWER indicator lights up and the headphones automatically starts to tune in to the signal from the base station (Auto Tuning function).

The AUTO SCAN indicator lights up when tuned in.

- **Press the center of the button firmly when pressing POWER. Pressing the edge may not turn on the power.**
- Charge the battery in the following cases.  
The battery ran out:
  - The POWER indicator does not light up after pressing POWER.
  - The AUTO SCAN indicator does not light up though the POWER indicator lights up.

- No sound is heard while Auto Tuning. It takes a few seconds to tune in.
- Press AUTO SCAN when the sound does not come out properly.



## 3 Adjust the volumes of the AV equipment and the headphones.



- Adjust the volumes within the area about 7 m from the base station to get optimum signal reception.
- You can get better sound by setting the volume of the AV equipment as high as possible without causing distortion and that of the headphone lower (except when connecting the AV equipment through LINE OUT jacks).

### To Turn off the units

Press POWER on the headphones and stop playback on the AV equipment. The headphones' POWER indicator goes off.



- The base station automatically turns off if no signals come in for about four minutes (Auto Power OFF function).
- The white noise may come out when the base station turns off. Take off and turns off the headphones after using.

# Basic operations

## Selecting a better reception channel

When the playback sound is noisy, you can choose one of the other two channels to transmit signals on the base station.

- The white noise may come out when switching the channel. Take off the headphones when switching the channel.

**1** Slide the **CHANNEL** selector on the back side of the base station to select another channel.



**2** Press **AUTO SCAN** on the headphones to tune in to the new channel.



**3** Repeat Steps 1 and 2 to select the best channel.

### Listening area

The headphones can receive the FM signal of the base station 100 m away from it at maximum (when no interference or obstacles exist between them). But the receivable range becomes shorter or reception quality becomes poorer in the following cases:

- In places such as reinforced concrete buildings
- Obstacles such as steel-reinforced doors exist between the base station and headphones
- Items such as metal furniture are situated nearby
- In places facing a street
- Noise or interference sources exist nearby (e.g. mobile ham, radio stations, high-voltage power lines, a microwave oven, cordless phones, cellular phones, etc.)

# Troubleshooting

What appears to be trouble is not always serious. Check the following points before calling a service center.

| Symptom                            | Cause/Remedy   |
|------------------------------------|--|
| No sound comes out at all.         | <ul style="list-style-type: none"><li>• Turns on the power of the headphones.</li><li>• Start playback on the AV equipment connected to the base station.</li><li>• Check the connection between the base station and the AV equipment.</li><li>• Turns up the volume of the headphones or the connected AV equipment to an appropriate level.</li><li>• Fully charge the headphones' battery.</li></ul>   |
| No sound comes out from R-channel. | <ul style="list-style-type: none"><li>• Check the connection between the base station and the AV equipment.</li><li>• Sound comes out only of L-channel when the base station is connected to the monaural audio output. Convert the mini plug to the base station from stereo to monaural with the plug adaptor (not supplied).</li></ul>   |
| Sound is distorted.                | <ul style="list-style-type: none"><li>• The headphones' battery will soon run out. Fully charge the battery.</li><li>• The volume of the headphones and/or the connected AV equipment is too high. Adjust their volume to an appropriate level.</li></ul>  |
| Sound is noisy.                    | <ul style="list-style-type: none"><li>• The headphones' battery will soon run out. Fully charge the battery.</li><li>• Switch the base station channel to another and press AUTO SCAN on the headphones.</li><li>• The volume of the connected AV equipment is too low. Adjust the volume as high as possible without causing distortion.</li><li>• Too far from the base station. Use the headphones within the range of the base station (see page 8).</li></ul> |
| Cannot charge the battery.         | <ul style="list-style-type: none"><li>• Check the contact of the charging terminals on the base station and the headphones.</li><li>• Check the polarity of the battery.</li><li>• The cycle life of the battery ended. Replace with the new battery (see page 6).</li></ul>   |

# Specifications

---

## General Specifications

|                                  |   |
|----------------------------------|---|
| Modulation system:               | Stereo frequency modulation system  |
| Carrier frequency:               | 863.5 MHz (Channel 1)<br>864.0 MHz (Channel 2)<br>864.5 MHz (Channel 3)         |
| Usable area (distance to reach): | Max. 100 m (using JVC measurement systems, under controlled ambient conditions) |
| Frequency response:              | 25 Hz – 13,000 Hz   |
| Distortion:                      | Less than 3% (at 1 kHz)   |

## Transmitter (J22321-001)

|                        |  |
|------------------------|--|
| Power requirements:    | DC 12 V (with the exclusive AC adaptor)        |
| Audio input terminals: | 3.5 mm dia. stereo mini jack                   |
| Input impedance:       | 36 k $\Omega$                                  |
| Reference input level: | 350 mV   |
| Dimensions:            | 159 (W) mm x 114 (D) mm x 123 (H) mm           |
| Mass:                  | 280 g (without connection cord and AC adaptor) |

## Headphones

|                       |  |
|-----------------------|--|
| Power requirements:   | Rechargeable Ni-MH battery (1.2 V) x 2 |
| Battery running time: | 10 hours (when charged for 30 hours)   |
| Mass:                 | 250 g (with rechargeable battery)      |

## Supplied Accessories

- Instructions x 1
- Exclusive AC adaptor x 1 (J34677-001: AC 230 V, 50 Hz, 7 W)
- Exclusive rechargeable Ni-MH battery x 2
- Connection cord x 1 (3.5 mm dia. stereo mini plug: 2.2 m)
- Conversion cord x 1 (3.5 mm dia. stereo mini jack — RCA pin plug x 2: 0.1 m)
- Plug adaptor x 1 (converts 3.5 mm dia. stereo mini plug to a 6.3 mm dia. standard stereo phone plug)

\* Design and specifications subject to change without notice.







HA-W600RF-B

FM CORDLESS HEADPHONES

**JVC**